

Houlihan & Co. (Excavations) Limited

OHSEQ Management System



<u>Project</u>	C/O Dandara Homes: Stortford Road, Great Dunmow.		
<u>Activity</u>	Houlihan has been contracted by Dandara Homes to carry out the groundwork operations for the new housing development, Stortford Road, Great Dunmow. As part of those works, Houlihans will carry out 278 works at Stortford Road.		
<u>No:</u>	<u>Doc. Ref</u>	M0622 MS 2501 – S278	Client: Dandara Homes

1.0	Project submission information	Document Prepared by:	Agron Selita	Signature:		Issue Date:	17.02.2026
		Document Reviewed by:	Conor Gough	Signature:		Issue Date:	17.02.2026
		Document issued to (Client):		Signature:		Issue Date:	17.02.2026

2.0	Document Control	Issue Date:	Amendment Number:	Date Amended:	Person Amending:	Remarks
		17.02.2026	0			

3.0	Document Contents	1.0	Project submission information	Page Number:	01
		2.0	Document Control	Page Number:	01
		3.0	Document Contents	Page Number:	01
		4.0	Site Description	Page Number:	01
		5.0	Scope of Works	Page Number:	03
		6.0	Preparation	Page Number:	03
		7.0	Access & Egress	Page Number:	04
		8.0	Supervision, Responsibilities and Site Organisation	Page Number:	04
		9.0	Labour, Management Resources & Training	Page Number:	04
		10.0	Major Plant & Minor Plant/ Equipment (Typical)	Page Number:	04
		11.0	Method of Work: Plant/ Materials and vehicle preparation and delivery	Page Number:	06
		12.0	Methodology: 278 Works	Page Number:	06
		13.0	Mains Drainage	Page Number:	09
		14.0	Method of Work: Adoptable & Private Road / Footpath Construction	Page Number:	14
		15.0	Method of work: Installing Services	Page Number:	15
		16.0	Method of Work: Work On/Near Underground Services	Page Number:	18
		17.0	Spoil Heaps	Page Number:	18
		18.0	Method of Work: Lifting with Excavator	Page Number:	20
		19.0	Method of Work: Working in confined spaces	Page Number:	22
		20.0	Health and Safety	Page Number:	22
		21.0	Discovery Strategy Contamination Waste Disposal	Page Number:	25
22.0	Silt Management	Page Number:	26		
23.0	Applicable COSHH	Page Number:	26		
24.0	Immediate Emergency Procedures	Page Number:	27		
25.0	Site Specific Risk Assessments	Page Number:	28		
26.0	Hand Arm Vibration & Decibel Level Reference Chart	Page Number:	40		
27.0	Communication: Confirmation of Operatives' Briefings	Page Number:	41		

4.0	Site Description Access & Egress	<p>The Site is located approximately 1.0 km west of the town centre of Great Dunmow, to the south of Stortford Road (B1256). It is rectangular in shape and consists of 10.7 Ha. To the north of the site is Stortford Road and Folly Farm, which include the residential dwellings. To the west are open fields designated for development into a school. To the east of the site is a new residential development under construction by Dandara Homes, while in the south is the Flitch Way (Public Right of Way with agricultural land beyond).</p> <p>The access into the site will be off the Stortford Road, the third exit of the roundabout into the shared driveway where the site entrance will be on the right-hand side. Applicable signage will be erected directing the construction vehicles to the site entrance.</p> <p>The site entrance will be clearly signposted. The construction plant will only be allowed to operate between the following hours:</p> <ul style="list-style-type: none"> • 8 am to 6 pm, Monday to Friday. • 8 am to 1 pm Saturday (only if required as per the construction programme); and • No work will be permitted on Sundays and Bank Holidays unless a requirement is identified under a statutory, i.e. Energy provider & Highways team. <p>No on-street parking is available on nearby local roads. On no account are the delivery drivers to use or turn into the mouth of residential road, going to neighbouring properties.</p> <p>Vehicles arriving outside normal hours will be turned away, and Houlihan & Co. will not be responsible for any costs incurred.</p> <p>The PC Site Traffic Management Plan also indicates the location of entrance/exit gates, laydown areas, and material storage areas.</p> <p>Vehicles will not be allowed to reverse out of the site access.</p>
------------	-------------------------------------	---

		<p>Restrictions on Site:</p> <ul style="list-style-type: none"> • Site entrance is a slip road and partially shared with a residential development, north of the site. Any vehicle manoeuvring must be done within the site boundary. • There is an Intermediate Gas main going along the southern boundary. This will be protected by a 5m easement. No work or storing materials is allowed within the easement. • TPO will be erected by others. No excavations or storing materials are allowed within TPO areas. • Demolishing/removal of the existing structure on site. It will be done by others and must be done before Houlihan gets PC
--	--	--

5.0	Scope of Works	<p><u>A Hold point has been introduced to our safe system of works company-wide,</u></p> <p>“Any remedial works required due to non-conformity or not to quality assurance and require remedial works that are not part of this approved safe system of works, shall be risk assessed, and remedial documentation produced where required”.</p> <p><u>278 Works</u></p> <p><u>5.1</u> Bellmouth <u>5.2</u> Footpath <u>5.3</u> Bus stop relocation <u>5.4</u> Adoptable Asphalt Carriageway <u>5.5</u> Adoptable Block Paved Carriageway <u>5.6</u> Adoptable Asphalt Footpath, Crossover & Cycleway <u>5.7</u> Private Asphalt Carriageway <u>5.8</u> Private Block Paved Carriageway <u>5.9</u> Private Asphalt Footpath, Crossover & Cycleway <u>5.10</u> Kerbs and Edgings <u>5.11</u> Street Furniture</p> <p>Note: Task-specific method statements & associated risk assessments will additionally be drafted at the health and safety representatives, site supervisors or site agents' discretion.</p>
------------	----------------	--

6.0	Preparation	<p>Pre-start on site:</p> <ul style="list-style-type: none"> • Works on Bellmouth will start only if Essex Highways approves the Permit. • The street works team will work within the traffic management area, which will be segregated with Chapter 8/Heras. • Traffic lights • Electric HV, water and other services present in the vicinity of work areas. • Once tarmac has been taken off Vac-Ex, hand digging only to take place • All operatives must be inducted and sign their appropriate RAMS. • No work to start before 08:00 in the morning. <p>Pre-Start Each day :</p> <ul style="list-style-type: none"> ○ Every morning before each shift, no operative / sub-contractor must commence work without attending a daily briefing held by the site work supervisor at the site compound no later than 0730hrs, where the day's task/s and associated risk/s will be addressed, planned and possibly challenged if operatives have any concern. ○ Toolbox talks/Task Briefing/Daily Briefings must be undertaken after the daily briefing with the operatives about to engage in high-risk work, such as excavating on/near live services / deep excavation activities/work in the public highway / confined space work, etc. ○ Check if there are any changes to the traffic management on site. ○ Pass 128 to have been carried out prior to works ○ Carry out a CAT scan survey in the proposed excavation areas routinely & review existing utility plans. ○ Ensure there are no other trades or public works along the line of the proposed works. ○ Check that all drawings are current and are the latest issues. ○ Cordon off the area of work from other personnel and traffic not involved in the work. ○ Ensure that the area of work is closed and that no access is permitted by the public. ○ Carry out Topographical Survey: Agree on levels with client. ○ The team or teams involved will carry out a task-specific briefing and sign off on it. If the work is on or near live services, the prestart procedure will also be followed. ○
------------	-------------	---

Houlihan & Co. (Excavations) Limited

OHSEQ Management System



7.0	Access & Egress	<ul style="list-style-type: none"> The access into the site will be off the Stortford Road, the third exit of the roundabout into the shared driveway. The site entrance will be on the right-hand side, and it will be clearly signposted A gateman will man the gate. There will be a jet wash to clean the wheels of the vehicles leaving the site. All Lorries and Traffic Movement will be banked around the site to the area of discharge /loading by training the banksman. No on-street parking is available on nearby local roads. There will be provision for vans to be unloaded on the site in a timed slot. On no account are HGV drivers to use or turn in the shared driveway of neighbouring properties.
8.0	Supervision, Responsibilities and Site Organisation	<ul style="list-style-type: none"> R. Gatward – Site Supervisor: 07880 501399 J. Barrowman – Site Engineer: 07516 754153 C. Gough – Contract Manager: 07947 984996 R. Carroll - Construction Director: 07884 490755 R. Knight - Managing Director: 07775 625 421 A. Selita - H&S advisor: 07507 430655 C. Gough – Temporary Work Coordinator: 07947 984996 J. Barrowman – Temporary Work Supervisor: 07516 754153
9.0	Labour, management resources & training	<ul style="list-style-type: none"> Sufficient time and resources will be made available to undertake the work involved. The works described will be undertaken by one gang of 5 operatives under the supervision of a competent Supervisor and Site Engineer. The Contracts Manager, Conor Gough, will visit the site at least once per week as required. Every morning before each shift, no operative / sub-contractor must commence work without attending a daily briefing held by the site supervisor at his site office no later than 0730hrs, where the day's task/s and associated risk/s will be addressed, planned and possibly challenged if operatives have any concern. Toolbox talks must be undertaken after the daily briefing with the operatives who are about to engage in high-risk work, such as excavating on/near live services, deep excavation activities, work in the public highway, confined space work, etc. Routinely carry out CAT scan surveys of proposed excavation areas and review existing utility plans when obtained, bearing in mind the constraints above. Note: when excavating on/near underground services, trial holes must be established to ascertain the line and depth of apparatus via the use of an air-pick and insulated shovels by trained and authorised personnel only. Only hand digging is to be conducted within 1 metre of services. Hand digging means using the air pick after removing the hard cover with bladed tools; it's only used to remove concrete pieces and rock that the air pick can't move. The depth of the hard cover will be determined by a trial excavation in an area without services, followed by horizontal excavation below the hard cover surface to establish a safe breakout depth for the machine. Ensure there are no other trades or public works along the line of the proposed works. Check that all drawings are current and the latest issue. Cordon off the work area from other personnel and traffic not involved in the work. Obtain a permit to commence works from the Principal Contractor. The Contracts Manager will report to our Construction Director, Richard Carroll, who will visit the site at least once per month. The Health and Safety Advisor, Agron Selita, will visit at least twice per month to monitor compliance with the Method Statement and risk assessments. He will also carry out re-inductions/inspections, investigate all site accidents and near misses, and review and approve subcontractors' RAMS. Where possible, a monthly joint visit with the Client H&S will be arranged. All our operatives have undertaken safety training. Our Managers and Directors have also attended CITB Safety Courses. All personnel have a schedule of health and safety (refresher) training in order to maintain our high standards. Machine operators are all certified to NPORS or CPCS standards, and copies of certification are held on site and readily available from the head office. Our entire workforce is undergoing on-site assessment via the CITB experienced worker route or has already achieved. This leads to National Vocational Qualifications in General Construction and Plant Operations for all relevant categories of operations or plant. Our whole workforce is accredited under the Construction Skills Certification Scheme (CSCS); all skilled groundworkers possess a blue Skilled Worker CSCS card; all labourers possess a green Labourers CSCS card as an absolute minimum and are working to gain NVQs. Note- All plant operators, regardless of cards carried, must be formally appointed as competent by our site supervisor, recorded on the H & Co plant operator authorisation register.
10.0	Major Plant & Minor Plant/ Equipment	<p><u>Major Plant (Typically):</u> JCB JS 135/140/160/220 6t/9t/10t forward tipping dumper 80/120/135 Ride on roller</p> <p><u>(Refer to H&Co's site safety OHSEQ notice board for current records & registers)</u></p> <p>Note: The machine operator completes all Weekly Check Sheets for 360°s and will always be available in the cab for inspection, including the most recent through-examination certificate. Copies are also kept in H&Co's site office (OHSEQ board).</p> <p>Excavators will have monitoring cameras fixed in the rear of the machine for all-around vision. Any machine that is not fixed with a camera and is not carrying out bulk earthworks will be accompanied by a Banksman. A Major Plant that does not have cameras fitted will achieve all-around vision using mirrors. We will continue to promote the "thumbs up" campaign Green flashing beacons are being progressively fitted across the Company. The new plant will come equipped.</p>



Banksman

- The banksman must be situated in a safe position and preferably outside of the operational area of the machine's fully extended boom, dipper and attachment.
- The banksman must face the operator when signalling and be clearly visible to them.
- The banksman must always maintain a clear line of sight with the excavator operator.
- The banksman must have direct sight of the load and lifting equipment at all times during the lifting operation and have adequate visibility of the load path.
- The communication between the operator and the banksman must be continuous throughout the duration of the lifting operation

Plant Operator/ 360° Machine Driver

- The operator must not respond to any hand signals (or other communication) that are not clearly understood and should seek additional clarification.
- Hand signals and any additional voice instructions should only be given by the identified banksman – except for an emergency stop, which can be given by any person, at any time, if a perilous circumstance is spotted.
- If other instructions are required (other than the agreed hand signals), then the operation should be stopped. Where there is any concern about the safety of, or the need to halt, the operation, all movement (and therefore any lifting or operation) should be stopped until the issue has been resolved to the mutual satisfaction of both the operator and the banksman. Comprehensive

Telescopic Handler JCB 535-125

JCB 525-125 will be utilised with the fork attachment to move Heras panels and on-site materials. The Telescopic handler operator will have the relevant NPORS/CPCS endorsements and will be competent to operate the plant. The telescopic handler operator will be briefed on his duties and made aware of any height restrictions set on site. A safety clearance of 5.3M will be achieved at all times.

- 3500kg Maximum lift capacity with stabiliser extended.
- 8.06m maximum forward reach with stabilisers extended
- To maintain stability, the telehandler should be used on firm level ground that resists sinking of the wheels or stabilisers.
- The telehandler should be stationary with the brakes applied, lifting normal loads.
- A marshaller will accompany all telescopic handler movements.
- Reversing is to be kept to a minimum with a marshaller present, and turning points are to be used when applicable.
- The operator should follow the manufacturer's instructions for travelling on slopes and inclines. It is essential that they do not attempt to climb, descend, or cross inclines in excess of the manufacturer's limiting values, as this significantly increases the likelihood of overturning.
- Daily checks will be completed every morning by the operator. If any issues are observed, do not operate the telescopic handler. Please notify the site supervisor and do not operate until remedial action has been taken.
- When travelling with a load, the load should point up-slope and tilted back, regardless of the direction of travel. This will keep the load from shifting and falling off the forks.
- When travelling without a load, the forks should point down-slope, regardless of the direction of travel. This will improve stability, traction and adhesion, and applies regardless of the direction of travel.
- Any loads should be strapped and properly secured on the grid of the forks.



		<p><u>Recovery of the overturned plant.</u></p> <ul style="list-style-type: none"> • In the event of an accident where a plant has turned over, the site supervisor and site manager must be notified immediately. • Assess the well-being of the plant operator. Call emergency services if a rescue operation is required. • Attend to the plant operator with first aid and call for an ambulance if he needs professional medical help. • Secure the area and notify the Houlihan Plant Department of the incident. Provide as much information as possible, such as the plant involved, the location on the site, any restrictions that could hinder the rescue operation, and any other specific risks within the area, which will help the recovery team plan. • The Plant Department will contact one of the approved Plant Recovery contractors closer to the site. • Site supervisor to ensure any leakage is contained within the area and does not go into the drainage or any water course. • The site supervisor will arrange for someone to meet with the Recovery team at the gate and accompany them through the site. • The Health and Safety department must be notified immediately. The incident will be investigated to identify the failures and contributory factors that led to it and establish control measures to prevent the repeat of similar incidents. <p><u>Minor Plant & Equipment (Typically):</u></p> <ul style="list-style-type: none"> • Block Grab • Concrete Skip/Bucket • Excavation Support Equipment • Setting out Instruments • Compressor & associated pneumatic tools • Heras Fence Panels / Avalon barrier • Shovels Inc. insulated • Hand Tools • Small electrical tools • Kerb lifter/ laying dolly • Block barrow • Pipe Lifter • Rammax • Concrete Skip / Pouring Bucket
--	--	---

11.0	<p><u>Methodology:</u> Plant/ Materials and vehicle preparation and delivery</p>	<ul style="list-style-type: none"> • Contract Manager and Site Supervisor to assess the works and identify the hazards and control measures that need to be put in place to avoid the exposure or to minimise the risk to a reasonably acceptable level. • They will be responsible for selecting the correct equipment for the task and the personnel trained to carry out the task. • A Task Activity Briefing must be held with the team carrying out the Task, and they must be briefed on the hazards identified, control measures that will be applied, plant and equipment used, work package plan, detailed drawing, and every member of the team must understand and sign the briefing sheet. • Work must stop when the weather conditions or any other circumstances change. The risks must be assessed and control measures applied to mitigate these risks before work commences. <p>Refer to RA_23 Unloading Vehicles</p> <p>Unless it is reasonably practicable to do so, the following safe systems of work must be followed at all times.</p> <ul style="list-style-type: none"> • Driver to have MS and RA in cab (supplier to have submitted this for approval by H & Co.). • The Low Loader Driver will sign in at the site entrance or Site Office prior to delivering the plant. • Plant deliveries are not to be made outside site working hours unless previously agreed upon with the Site Manager. • Lone Working is not permitted, and deliveries are not to be made unless a member of staff is present on site. • Plant deliveries are not to be made in areas where adequate lighting is not present. • The vehicle collecting the plant shall be a vehicle designed for the collection, transportation and delivery of mobile plant, be it wheeled or tracked. Low Loader. • The vehicle must have a suitable means of getting the plant onto the trailer and will include designed loading ramps. • The Low Loader driver must be a competent person trained in the loading/unloading of all categories of plant from the lorry and for its security during transport. • All loading/unloading operations shall be supervised by a competent person. The Low Loader driver shall act as the competent person. • All plant shall be loaded/unloaded onto the low loader by a competent plant operator only and directed by the lorry driver only. No other person shall undertake these instructions. The low loader driver can unload the plant provided he is qualified to do so. • During the plant loading/loading operations, all persons other than the plant operator and lorry driver shall stand away out of the loading area. • During access to the lorry platform, if there is a risk of personal injury from a fall, a means of preventing a person from falling off needs to be installed, or the use of a safety harness must be implemented. All such persons shall be trained in the risks of falling from the lorry platform and in how to control those risks. Where clients provide access platforms/podiums, these must be used. • Prior to moving all loaded plant, it shall be adequately secured by the appropriate means, such as chains, etc., by the low-loaded driver only, or assisted by others working under his instructions
-------------	---	--

		<ul style="list-style-type: none"> The driver shall determine the route and final resting place of all plant to be loaded/offloaded before the activity commences. The driver shall also ensure the plant/materials loading/unloading route is clear of all hazards, obstructions, restrictions, etc., if the operations commence. All suppliers have been asked to work to industry guidance rework at height on their vehicles- a solution for each load will have been determined before the load is dispatched- loads which cannot be safely unloaded will be turned away. Loads depending on banding or shrink wrapping must be strapped to include each row, and in addition, strapped twice perpendicular to the straps on each row. <p>Note: no individual must enter the bed of a lorry without edge protection.</p>
--	--	---

12.0	<p><u>Method of work</u></p> <p>278 Works – Bellmouth Works</p>	<ul style="list-style-type: none"> Contract Manager and Site Supervisor to assess the works and identify the hazards and control measures that need to be put in place to avoid the exposure or to minimise the risk to a reasonably acceptable level. They will be responsible for selecting the correct equipment for the task and the personnel trained to carry out the task. A Task Activity Briefing must be held with the team carrying out the Task, and they must be briefed on the hazards identified, control measures that will be applied, plant and equipment used, work package plan, detailed drawing, and every member of the team must understand and sign the briefing sheet. Work must stop when the weather conditions or any other circumstances change. The risks must be assessed and control measures applied to mitigate these risks before work commences. Make sure the operatives have received Houlihan’s “Digging on/or round live services” and they have signed to the Designated RAMS for this procedure and hold NRSWA. The site supervisor NRSWA must be on site at all times to supervise the dig team. The dig supervisor must never leave the dig area. If he is not present, the operation must stop. Wear the appropriate PPE for the task. Specifications as per Essex Highways requirements PASS 128 must take place prior to any work starting Check the service drawings to determine the number of cables, voltage rating, and physical dimensions of the cable(s). Use a cable avoidance tool (C.A.T. & Transmitter) to trace the cables’ line and mark their route on the ground. The supervisor or Engineer must carry out this task only. The EZiCAT i750, with depth locator, memory, GPS, and Bluetooth, will be used at minimum. Trial Holes to be carried out to identify services. Take a copy of the permit and armband issued with you to the dig area. The foreman will consult with the client and agree on the areas for the works to commence. Signage and chapter 8 barriers will be erected to segregate the works area from traffic and other members of the public due to works being carried out on the road. H & Co to commence the work starting with a detailed survey of the area for live cables and services using a Cable Avoidance Tool and hand excavation methods to ascertain the actual line and level of underground apparatus that could be encountered, mark and plot all live services encountered on a relevant drawing. Once the tarmac has been removed, only Vacex/ hand dig/air pic will be utilised around any services. If medium-pressure gas is in the vicinity of work, relevant service providers must be informed, and only when approved by the service providers, work commences. <p>Bellmouth Formation</p> <ul style="list-style-type: none"> Mark the area to be excavated as per Bellmouth design – refer to drawings: The excavated material will be removed directly in tipper trucks to avoid double handling and stored on site. If the material is suitable for reuse, stockpiles will be required – All stockpiles must be managed to allow safe access for dumpers with shallow gradient ramps and bunded sides. Excavate the road to formation level using traveler and profile boards, as set out by the site engineer. If possible, excavations should be dug from reduced levels and backfilled on the same day, thus avoiding any risks that open excavations would incur. Offer formation to the client for approval: HOLD POINT One person will inspect the formation to confirm uniformity and compliance with the specifications. Lay Formation subject to CBR-s. Refer to drawings for material type and depth of each layer Subbase type 1 material to clause 803 of the specifications for highway works. Fill material to be compacted in layers not exceeding 150mm thick. <p>Tarmacing – Will be carried out by Andersons Tarmacers(RAMS will be provided)</p> <p>All such works will be carried out as per Essex Highway Specifications – refer to the relevant drawings for details.</p> <ul style="list-style-type: none"> Base layer Binder course Surface course White lining <p>Footpath Construction – Refer to relevant drawings for specifications</p> <ul style="list-style-type: none"> Mark out footpath area. Excavate to required depth. Store spoil safely or remove from site. Maintain safe edges and access routes. Lay geotextile if required. Install Type 1 sub-base in layers. Compact using plate compactor/roller. Check levels and falls. Lay base course or bedding layer.
-------------	---	---

	<ul style="list-style-type: none"> • Tarmac surface. • Compact and finish. <p>Kerbs & Edgings</p> <ul style="list-style-type: none"> • New kerb and edging lines will be set out using non-penetrating cantilevered 'pin-safe' with "top of kerb/ edging" levels marked. • The excavator will conduct minor excavations to provide suitable depth for kerb /edging and concrete bedding. <p>There are 2 options relating to initial kerb installation:</p> <p>Option 1 - Sacrificial full-height kerbs to retain the edge of the roads.</p> <ul style="list-style-type: none"> • Kerbs will be loaded out by the tracked excavator using lifting straps or, alternatively, forklift attachment and will deposit each stack at a suitable position along the kerb line. • Kerbs will then be installed or deposited from the pallet using the Probst kerb laying dolly, as close to the proposed kerb line as possible. • The concrete will be distributed by the excavator bucket to the line. • Concrete will be manually levelled under the string lines and will be left approx. 20mm high to allow for bedding of the kerb. • For Kerbs that aren't able to be finally placed by the Probst kerb dolly, two skilled groundworkers will use the 'bicycle handle type' kerb lifter and finally lift them into their proposed position <p>Note: Under no circumstance should anybody use the 'bicycle type' handle lifter as their primary laying process; it should only be used where the Probst kerb dolly is limited in use. Once kerbs have been placed on the concrete bed and aligned/levelled, they will be levelled using a pick.</p> <p>Option 2 – 7N concrete blocks used as templates.</p> <ul style="list-style-type: none"> • Blocks will be loaded out by the tracked excavator using lifting straps or, alternatively, forklift attachment and will deposit each stack at a suitable position along the kerb line. • The concrete will be distributed by the excavator bucket to the line. • Concrete will be manually levelled under the string lines and will be left approx. 20mm high to allow for bedding of the kerb. • Blocks will then be manually placed in accordance with the engineer's pins and string line. • Bedding and hunching concrete will be delivered to the site ready mixed and will be deposited in a stockpile. • Following kerb/ block installation, all iron works will need to be raised to base course level to avoid subsequent damage or residual trip hazards. • Carry out final preparation to sub-base using the excavator and Bomag roller. • Base course tarmac will either be installed by us or a specialist contractor, depending on road features and quantity. The base course tarmac if installed by us will typically be levelled off by a 360 excavator and rolled in accordance with the relevant specification. <p>Note: Edgings will be installed in a similar method to the installation of concrete 7N blocks.</p> <p>Relocation of Bus stop</p> <p>Isolate work area.</p> <p>Remove sign, pole and timetable case. Remove shelter (if applicable). Break out existing concrete base. Remove tactiles and paving if needed. Dispose of waste appropriately. Excavate for new pole/shelter base. Excavate footpath for new tactiles. Install sub-base and compact. Pour concrete foundation/tarmac for pole/shelter. Allow curing time.</p> <p>Raise Ironworks.</p> <p>Enclose the work area with half-height barriers. Ch 8 signage will be used to direct other on-site trades away from the area of work and the access and egress routes to it. Using a Petrol Saw with a water-suppression pressurised pump, the retaining material will be scored, broken, and transported to a stockpile for reuse or removal. The engineer will give the finished road level and camber, operatives will lay the ironworks to these levels. Engineering brick will be laid on a bed of mortar, with a minimum of 2 courses and no more than 4 courses. The cover will be laid to line and level and surrounded by concrete to the underside of the tarmac level. The concrete will be allowed to cure, and tarmac will be called to the site, laid, levelled and compacted.</p>
--	--

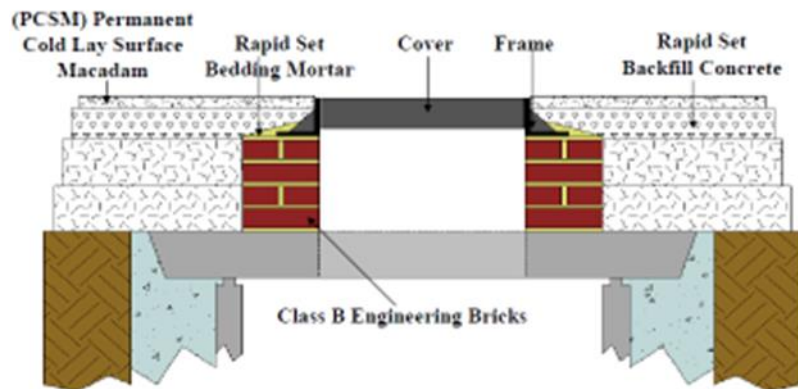

Street Lighting

Such works will be carried out by a subcontractor

Tactiles

- Confirm location and layout from drawings.
- Check orientation of tactiles (blisters must face correct direction toward crossing).
- Set out area using string line.
- Check for underground services.
- Excavate to required depth
- Ensure formation level is even and compact.
- Remove spoil to designated area.
- Lay mortar bed (typically 30–40 mm) or sharp sand as specified.
- Screed level and to required falls.
- Do not lay too large an area at once to avoid drying.
- Place slabs carefully onto bedding.
- Ensure correct orientation (blister rows perpendicular to crossing).
- Tap down with rubber mallet to level.
- Maintain consistent joints (approx. 5 mm).
- Check alignment with string line.

13.0	<u>Methodology:</u> Mains Drainage	<ul style="list-style-type: none"> • Contract Manager and Site Supervisor to assess the works and identify the hazards and control measures that need to be put in place to avoid the exposure or to minimise the risk to a reasonably acceptable level. • They will be responsible for selecting the correct equipment for the task and the personnel trained to carry out the task. • A Task Activity Briefing must be held with the team carrying out the Task, and they must be briefed on the hazards identified, control measures that will be applied, plant and equipment used, work package plan, detailed drawing, and every member of the team must understand and sign the briefing sheet. • Work must stop when the weather conditions or any other circumstances change. The risks must be assessed and control measures applied to mitigate these risks before work commences. <p>Refer to</p> <p>RA_12 Excavations / Trenches RA_11 Operating 306° Excavators RA_10 Operating Forward Tipping Dumpers RA_06 Cutting Concrete, kerbs, blocks, edges, pipes. RA_38 Pouring Concrete</p> <p>Installing the Proprietary Trench support – Trench Box, Manhole Box, Trench Sheet Piled</p> <p>COSHH – Wet Concrete / Mortar Silica Cement Petrol</p> <p>HAV / Decibel Chart for the Petrol Saw</p> <p>21 MoW Lifting with excavators and Lift Plan – for lifting pipes, manhole rings, and bases into position.</p> <p>Setting out / Earthwork preparation & installing proprietary support systems:</p> <p>All excavation works will be carried out in accordance with Construction (Design and Management) Regulations 2015 and the Guidance from the CPA</p>
-------------	---------------------------------------	---

"Be Safe - Shore" guide to Trenching Practice.

- Set out the extent of the run/s, ideally commencing from the terminal connection or lowest point.
- The foul drainage is gravity run, and the connection point is on the site entrance.
- The storm water drainage will have two separate runs discharging into the ditch on the northern border and the other one at the new pond that will be constructed in the open space on the southern side of the site.
- The foul drainage will be mainly clay pipes of the 100Ø mm.
- The storm water drainage pipes vary from 150Ø and 225Ø clay pipes and 300Ø mm, 375Ø mm and 525Ø mm concrete pipes.
- The extent of the proposed drainage run must be subject to a reduced level dig, so drainage trenches are dug at reduced levels; ideally, below the proposed road formation/level.
- Identify and supply appropriate earthwork support – such as proprietary trench and manhole boxes. Note: support systems must be set up in accordance with the preferred supplier's installation guidance.
- Conduct existing survey investigations, to include marking on the ground any potential services in close proximity with the use of CAT, excavating trial holes to ascertain actual line and depth.
- Identify access, movement and storage areas and erect safety exclusion fencing to enclose the works.
- The perimeter of the proprietary earthwork support systems should be sprayed on the ground of the proposed dig so that the excavator operator can cut the trench/ excavation tightly and ultimately prevent voids around the in-situ boxes.
- Commence excavation, initially to a suitable depth to allow installation of the trench box, typically 1.00m below ground level (bgl).

Please note that in unstable conditions, the box would be installed at a higher level and would be adjusted as the excavation proceeds.

- In excavations 2.4m and below, it will be necessary to use an additional base or top box section or to terrace the top of the excavation – ensure handrails and ladder access platform are installed.
- Remove all excavated material from the excavation area to prevent imposing an unnecessary load onto the excavation face. – The material should be kept to a minimum of the excavation depth away, and immediately used for backfilling as soon as the earthwork support system has been extracted.
- Installation of the box by hooking a suitable set of 4 leg chains to the specified lifting eyes, attached to the designated lifting eye on the 360° excavator's quick hitch.
 - Continue excavation within the confines of the box to the intended level.
 - Where there is doubt, provide gas testing/monitoring equipment and fix it at an appropriate position in the excavation to ensure safety.
 - Place clean, washed shingle/concrete bedding using the excavator bucket. Materials will generally be discharged into a drag skip or alternatively into the skip of a dumper.
 - During the placement of any material/product into trenches, all operatives must evacuate the excavation.
 - Dumpers must not directly tip into the trench.

Recommended excavator bucket selection (mm) versus pipe diameter (Ø mm):

150Ømm – 450mm / 225Ømm – 600mm / 300Ømm – 600mm / 375Ømm – 750mm / 450Ømm – 750mm / 525Ømm – 750mm / 600Ømm – 900mm / 675Ømm – 900mm / 750Ømm – 900mm / 900Ømm – 1200mm or 1350mm / 1050Ømm - 1200mm or 1350mm / 1200Ømm – 1500mm or 1800mm / 1500Ømm – 2100mm

Pipe laying (clay): Nominally foul sewers

Clay pipe weights: Suitable to manually lift / Unsuitable to manually lift

100Ø x 1.6m (L) weigh 15kgs / 150Ø x 1.00m (L) weigh 18.5 kg / 150Ø x 1.75m (L) weigh 31 kg / 225Ø x 1.75m (L) weigh 61 kg.

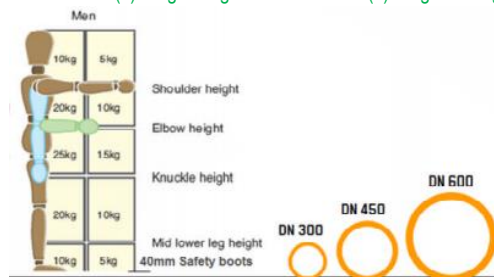

- Pipe laying will commence and should (but not always necessary) start at the downstream end, the pipes being usually laid with the sockets upstream.
- Operatives can manually place pipes of 150Ø or below, depending on the excavation depth; pipes can be passed down or lowered manually, utilising a web sling. Pipes will be aligned using either a string line or pipe laser, as appropriate.
- Ensure that the inside of the coupling and the exterior of the spigot are clean.
- Spread a layer of lubricant over the pipe end to the required insertion depth and push the coupling home onto the pipe.
- The pipes shall be laid true to the line and level within tolerances specified by the design. Any necessary adjustments to the level shall be made by raising or lowering the bedding, always ensuring that the pipes are finally provided with support along their whole length. Adjustment to level and position shall not be made by local packing.
- Lower the next pipe into the trench, inserting the pipe end into the mouth of the previously laid coupling and align the pipe along the central axis of the pipeline. Apply a forward horizontal pressure, combined with a small side-to-side movement, and push the pipe home into the sleeve coupling.
- All pipe laterals must be capped with suitable plugs/caps – not crunched up bags/packaging, etc.
- Each run or section will be tested before and after backfilling. This will be carried out in accordance with the recommendations set out in BS EN 1610:2015.

- The larger pipes 225Ø+ will be placed by the excavator, pre-slung with 2x web-slings by a slinger/signaller and lowered into position in the excavation. Note – there must be no operative within the proprietary earthwork support system whilst any load is being slung overhead – especially clay pipes, due to their vulnerability to shattering, which can produce razor-sharp fragments.
 - For pipes 225Ø+ will require gentle prizing home using a metal bar and a small section of 4"x 2" timber as per the images below.
- See installation images below:



Pipe cutting (Clay):

- Pipe chain cutter for 100Ø & 150Ø pipes - Cutting shall be performed with the correct tools and as recommended by the pipe manufacturer; cuts shall ensure adequate performance of the ensuing joint.

*This procedure should be followed to ensure a good quality cut with a Lever action pipe chain cutter (100mmØ & 150mmØ clay pipes **MUST** be cut with a pipe chain cutter as follows):*

- Make a clear mark around the circumference of the pipe at the desired length.
- Pass the chain under the pipe, aligning the cutting wheels on the desired mark.
- Hook the chain link onto the jaw of the pipe cutter.
- Tighten the chain upon the pipe by closing the arms of the lever cutter together.
- Make a final check for the chain's correct alignment with the pipe, then continue to increase the chain tension until the pipe cuts.
- After cutting, any sharp edges may require trimming with an emery stone. Use a pipe trimmer for both 100mm and 150mm diameters.

Powered Masonry Saw:

- A powered masonry saw can be used to cut any diameter of pipe we use. Generally, 100Ø & 150Ø diameter pipes are cut with a pipe chain cutter for speed and efficiency.
- All persons operating power saws are to be trained to use abrasive wheels.
- 225 & 300Ømm pipes are generally cut by a powered masonry saw, using a diamond-tipped blade.
- When using a powered masonry saw a safe system of work should be followed: Note only appointed and authorised individuals should use an abrasive wheel.
- Before any pipe cutting operation is started, read and adhere to the safety and operating instructions of both the masonry saw and the blade manufacturer.
- Check that the masonry saw is fitted with the correct blade specification.
- Make a clear mark around the circumference of the pipe at the desired length.
- The pipe being cut should be positioned in a horizontal and stable position.
- Care should be taken to support and secure both halves of the pipe being created by the cut, to avoid the blade being nipped as the pipe separates.
- With the correct personal protective equipment in place, commence the cut; the best quality cut is generally achieved by making one continuous cut.
- After cutting, any sharp edges may require trimming with an emery stone.

Note: Short-length pipes should be ordered directly from the preferred supplier to minimise on-site cutting operations.

Backfilling:

- Withdraw earthwork support when backfill reaches the underside of waling.
- In the first stages of backfill, selected material should be placed uniformly on both sides of the pipe by hand in layers not exceeding 100mm in thickness, each layer being compacted by hand tamping until the pipe has a minimum of 150mm compacted cover.
- Further backfill should be placed in layers not exceeding 300mm, each layer being well compacted. Mechanical compaction equipment should not be used until there is a minimum of 450mm of compacted material above the crown of the pipe.

Pipe laying (PCC): Nominally surface water

PCC pipe weights: Suitable for manual lifting / Unsuitable for manual lifting

225Ø x 1.25m (L) weigh 122kg / 300Ø x 1.25m (L) weigh 217kg / 300Ø x 2.05m (L) weigh 420 kg / 375Ø x 2.5m (L) weigh 510 kg / 450Ø x 2.5m (L) weigh 705kg / 525Ø x 2.5m (L) weigh 900kg / 600Ø x 2.5m (L) weigh 1200kg / 675Ø x 2.5m (L) weigh 1275kg / 750Ø x 2.5m (L) weigh 1924kg / 825Ø x 2.5m (L) weigh 1820kg / 900Ø x 2.5m (L) weigh 1920kg / 1050Ø x 2.5m (L) weigh 2590kg / 1200Ø x 2.5m (L) weigh 3550kg.

- Once the trench has been excavated to the specified line and levels, and the proprietary earthwork support system has been adequately installed with attached handrails and ladder access platform.
- Before lowering into the trench, each unit should be inspected carefully for any damage which may have occurred in transit or during handling and storage on site. Pay special attention to jointing surfaces. Units should be lowered carefully into the trench using tackle suitable for their weight and the trench depth.
- Pipe laying will commence and should start at the downstream end, the pipes being usually laid with the sockets upstream.
- Trenches should be kept to the specified width since any increase in trench width will increase the load on the pipe, the quantity of excavation

and will also require more bedding material.

Using a proprietary pipe-lifter:

Pipe lifters are specifically designed to allow excavators to quickly and efficiently pick up and place a wide range of concrete pipes without the need for an operative to contact either the pipe or the pipe-lifter.



No operative should be within the excavator's fully extended radius in transit.

All users must be familiar with the pipe lifters manufacturer's user guide.

Prior to delivery of any concrete pipe, ensure the correct pipe lifter head is compatible with the appointed excavator/s.

The pipe lifter must have a current thorough examination certificate valid within 6 months. This certificate must also be logged on the OHSEQ site notice board clipboard—lifting accessories register.

The most common pipe lifter we use is from MGF. This particular item has been tested to a SWL of 3.7t and designed for use with collared concrete pipes ranging from 300Ømm to 1200Ømm, with a maximum length of 2.6m (our max purchased pipe length is 2.5m).

The (ouring plate has TWO available settings: an upper hole for clamping 300Ømm - 450Ømm pipes and a lower hole for use with 525Ømm - 1200Ømm pipes. (see photograph below).



If the adjustment is required to be undertaken on-site, ensure this is carried out whilst the lifter is stabilised and contained within its stillage. Two operatives are required to perform the task. Remove the securing bolt and collar, and carefully remove the 40mm-diameter pin. Reposition the clamp to the required hole, slide the pin back into place, slip the collar over, and tighten the M10 bolt.

When the pipe-lifter is not in use, it must be placed in a bucket/attachment area for safe storage and coupling.

When the pipe-lifter has coupled a load and raised it 2 feet above ground level, the operator must confirm that the load is stable by tilting the pipe + & - 15° from horizontal.



If the pipe is stable and correctly coupled, the pipe may be lifted and transferred to a suitable storage location or placed into a prepared trench and jointed following the application of a lubricant to the pipe spigot and visual inspection of the socket profile, checking for any fractures or obvious damage. Note: care should be taken to prevent the lubricant from contacting the pipe or equipment, as this can cause the pipe to slip.

Pipes being lifted must be kept as near the ground as is practicable and never lifted over operatives.

Upon reaching the trench with the pipe attached and the excavator stabilised, it will carefully begin to lower the pipe into the required position.

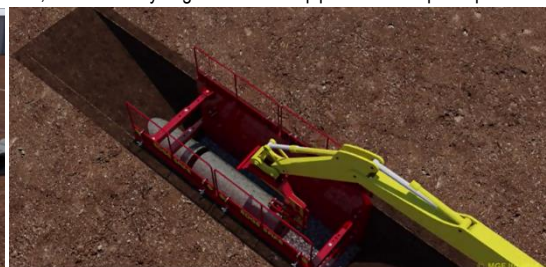

- The pipe may be tilted up to 30° from horizontal and manoeuvred between the struts of the trench box. During the operation, ensure neither the pipe lifter nor the pipe snags other equipment or the ground, as this could lead to a dangerous release of the pipe lifter.
- For all operations, ensure that the pipe is being laid on suitable ground/bedding and the pipe is chocked/backfilled to prevent unexpected movement.

- The pipe lifter can be used to push the pipe into position – care must be taken when jointing to ensure even pressure is being applied to the gasket. – No personnel should be in the working area or come into contact with the pipe-lifter/ excavator / any pipe in transit/installation.
- IF personnel are required inside the trench, then the operative must stand well behind the collar of the previously installed pipe (as per the illustration below).



Alternatively, if a pipe lifter cannot be used due to size or weight

- Jointing chains or appropriate straps can be utilised to carefully lift and guide pipe spigots into the previously laid pipes' sockets, taking care not to disturb the jointing ring/damage the jointing surfaces.
- The spigot should be offered up to and centred carefully into the receiving socket.
- The pipe can now be allowed to rest on the bedding material (alternatively, the pipeline can be back-laid, i.e. new pipes laid with the socket offered up to previously laid pipes' spigot – special attention should be made to ensure the socket does not scoop up bedding material and hence contaminating the joint when laid using this method).
- The sling must be wrapped around the barrel of the pipe in a choke at the balance point. Position the bight for the choke lift at 120° (natural angle) – as per the sketch below:

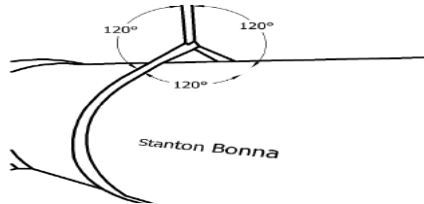

Using the excavator bucket or pulling the pipe home with a strap/jointing chain, which are common methods of completing the joint. If using the excavator bucket to push the pipe home, always place a timber between the back of the bucket and the pipe's socket (spigot if back-laying). Apply steady, even pressure until the pipe is in its final jointed position, with the joint gap within the recommended limits of 10-25mm (joint gap measured internally).

ENSURE NO OPERATIVES ARE WITHIN THE TRENCH WHILST THE BUCKET IS APPLYING PRESSURE AGAINST THE TIMER PUSHING THE PIPE INCASE THE TIMBER BREAKS AND STRIKES AN OPERATIVE IN CLOSE PROXIMITY – NOTE THIS HAS HAPPENED WITHIN THE INDUSTRY BEFORE AND RESULTED IN A FATALITY.

As shown below: (Jointing with the excavator bucket).

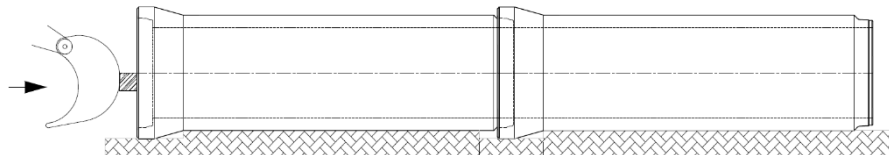

Note: The Mechanical plant must not be used to press pipes down to their correct level.

Groundwater should be kept below the bottom of the trench by the use of temporary drains and not allowed to rise before backfilling is complete.

All pipelines, especially those for foul sewers, are tested after each independent pipe is laid, and prior to backfill.

Manhole installation:

Recommended excavation size / manhole box to suit manhole Ø mm:

Manhole Ø	Square Manhole box dimensions	Comments
1050Ømm, 1200Ømm, 1350Ømm	2.5m(L) x 2.5m(W)	1350Ømm (tight)
1350Ømm, 1500Ømm, 1800Ømm	3.0m(L) x 3.0m(W)	1800Ømm (tight)
1800Ømm, 2100Ømm	3.5m(L) x 3.5m(W)	2100Ømm (tight)
2100Ømm, 2400Ømm, 2700Ømm	4.0m(L) x 4.0m(W)	2700Ømm (tight)
2700Ømm, 3000Ømm	4.7m(L) x 4.7m(W)	None
3000Ømm, 3660Ømm	5.0m(L) x 5.0m(W)	None

Manhole excavations will be conducted/supported similarly as previously mentioned drain runs and will have PCC chamber sections placed by the attendant excavator.

- Again, operatives will leave the excavation until the PCC chamber ring is near the intended position and is stable.
- The section will then be manually guided into the final position on the concrete/shingle bed or the previous section.

Note – the second and subsequent PCC rings must not be installed until all benching has been undertaken.

		<ul style="list-style-type: none"> Once the benching has been undertaken with the additional sections installed, and the manhole is a traditional type (not pre-formed), a concrete manhole surround steel shutter will be lifted into place with the inclusion of the surround safe handrails. Once the concrete has cured, the shutter will be removed, and the cover slab will be lifted into position; there are usually lifting anchors on the face allowing the use of hook and chain. <p>Backfilling:</p> <ul style="list-style-type: none"> Withdraw earthwork support when backfill reaches the underside of waling. In the first stages of backfill, selected material should be placed uniformly on both sides of the pipe by hand in layers not exceeding 100mm in thickness, each layer being compacted by hand tamping until the pipe has a minimum of 150mm compacted cover. Further backfill should be placed in layers not exceeding 300mm, each layer being well compacted. Mechanical compaction equipment should not be used until there is a minimum of 450mm of compacted material above the crown of the pipe. <p>Producing as-built drawings & testing:</p> <p>On completion, the run will be marked on the as-built record drawing together with dates of test & inspections.</p> <p>Emergency Plan:</p> <ul style="list-style-type: none"> If there is an emergency at the bottom of an excavation, then initial assessment by first aiders will establish if the IP can be moved or must be stabilised in situ pending the arrival of paramedics. Until and unless agreed, the first treatment can be carried out in situ, and preparation for paramedic access and subsequent evacuation by stretcher will immediately begin. In the event of evacuation being necessary, this will be achieved down to 5.0m. BGL by the excavator pulling a ramp in the direction of the run being pulled to an angle of approximately 20°. The sides of this ramp will then be reduced to allow paramedics safe access and egress. If the ramp cannot be pulled in the direction of the run, the excavator will move around to the opposite end of the boxes, where the pipework has already been installed, and a ramp will be constructed in the opposite direction to the run. Below 5.0m. A davit arm will be provided and attached to the box side. A rescue stretcher will be available at ground level for deployment as necessary.
--	--	---

14.0	<p><u>Method of work</u></p> <p>Adoptable & Private Road / Footpath Construction</p>	<ul style="list-style-type: none"> Contract Manager and Site Supervisor to assess the works and identify the hazards and control measures that need to be put in place to avoid the exposure or to minimise the risk to a reasonably acceptable level. They will be responsible for selecting the correct equipment for the task and the personnel trained to carry out the task. A Task Activity Briefing must be held with the team carrying out the Task, and they must be briefed on the hazards identified, control measures that will be applied, plant and equipment used, work package plan, detailed drawing, and every member of the team must understand and sign the briefing sheet. Work must stop when the weather conditions or any other circumstances change. The risks must be assessed and control measures applied to mitigate these risks before work commences. <p>Refer to</p> <p>RA_12 Excavations / Trenches RA_11 Operating 306° Excavators RA_10 Operating Forward Tipping Dumpers RA_33 Ride on Roller RA_14 Hand Laying and Compacting Tarmac Surfaces. RA_29 Tarmac Surfacing RA_18 Laying Kerbs RA_19 Laying Slabs RA_06 Cutting Concrete, kerbs, blocks, edges, pipes. RA_38 Pouring Concrete</p> <p>Installing the Proprietary Trench support – Trench Box, Manhole Box, Trench Sheet Piled</p> <p>COSHH – Wet Concrete / Mortar</p> <p style="padding-left: 20px;">Silica Petrol</p> <p>Preparation:</p> <ul style="list-style-type: none"> The foreman will consult with the client and agree on the areas for the work to commence. Signage and barriers will be erected to segregate the works area from other trades and members of the public (if applicable). H & Co to commence the work, starting with a detailed survey of the area for live cables and services using a Cable Avoidance Tool and hand excavation methods to ascertain the actual line and level of underground apparatus that could be encountered, mark and plot all live services encountered on a relevant drawing. <p>Haul Road Construction (Hard Stand for Compound)</p> <ul style="list-style-type: none"> Terram 100 will be laid at the formation, and the site foreman will call for crushed concrete to be delivered to the site. The lorries will back up at the site entrance and offload onto the Terram. The 360° excavator will spread and level the crush, and track it in (normally on a 150mm layer ready for compaction, 200mm depth) Once level, a twin-drum vibrating roller will compact the crushed material using a sufficient number of passes (6 passes). A turning point will be constructed as soon as possible to avoid the need for lorries to access the side reversing. Edges of layers shall be benched to provide full compaction of subsequent fill layers against a leading or open edge.
-------------	--	---

		<p><u>Tarmac Road Formation</u></p> <ul style="list-style-type: none"> Excavate the road to formation level using traveler and profile boards, as set out by the site engineer. If possible, excavations should be dug from reduced levels and backfilled on the same day, thus avoiding any risks that open excavations would incur. The excavated material will be removed from the site directly in tipper trucks to avoid double handling. If the material is suitable for reuse, stockpiles will be required. All stockpiles must be managed to allow safe access for dumpers with shallow gradient ramps and bunded sides. Excavate the road to formation level using traveller and profile boards, as set out by the site engineer. If possible, excavations should be dug from reduced levels and backfilled on the same day, thus avoiding any risks that open excavations would incur. A level survey will be carried out in all areas prior to the commencement of grading works, which will be undertaken by a 360° excavator to achieve the correct construction depths. Offer formation to the client for approval: HOLD POINT The formation will be inspected to confirm uniformity and compliance with the specification. Lay Terram and cap Formation once approved. Install formation material to the underside of the Tarmacadam level. A capping layer of 380mm of 6F2 will be installed and compacted. A layer of 230mm of type 1 granular sub-base will be laid and compacted. The approved subbase layer will be formed to a nominal 100mm thickness and compacted using a twin-drum vibrating tandem roller (Bomag 120). Compaction shall be a minimum of 1 No "dead-roll" pass, 6 no passes on full-service vibration, and a further "sealing" pass to close the upper surface and remove "tram lines." A specialist contractor will later apply a 60mm binding course, followed by 20mm and 30mm wearing courses of 10mm tarmac in one go. The tarmac base will be formed using 200mm of AC32 base course. It will be compacted using a twin-drum vibrating tandem roller (Bomag 120). Compaction shall be a minimum of 1 No "dead-roll" pass, 6 no passes on full-service vibration, and a further "sealing" pass to close the upper surface and remove "tram lines." A specialist contractor will later do a 60mm binding course using AC20 tarmac and AC10 tarmac of 40mm wearing courses in one go. <p><u>Final Wearing Course Road Surfacing</u></p> <ul style="list-style-type: none"> The sacrificial kerbs and existing bedding will be removed; all new kerbs will be bedded on a new bed. The road will receive a final clean in preparation for wearing the course tarmacadam. An appointed specialist contractor will then undertake the required tarmac resurfacing works.
--	--	---

15.0	<u>Method of work</u> Installing Services	<ul style="list-style-type: none"> Contract Manager and Site Supervisor to assess the works and identify the hazards and control measures that need to be put in place to avoid the exposure or to minimise the risk to a reasonably acceptable level. They will be responsible for selecting the correct equipment for the task and the personnel trained to carry out the task. A Task Activity Briefing must be held with the team carrying out the Task, and they must be briefed on the hazards identified, control measures that will be applied, plant and equipment used, work package plan, detailed drawing, and every member of the team must understand and sign the briefing sheet. Work must stop when the weather conditions or any other circumstances change. The risks must be assessed and control measures applied to mitigate these risks before work commences. <p>Refer to RA_12 Excavations / Trenches RA_11 Operating 306° Excavators</p> <p>Preparation Before any work is carried out, the following items must have been completed, and copies of relevant documents must be available at the site of the works:</p> <ul style="list-style-type: none"> Accurate plans showing all existing services in the vicinity of the work site. Plan of proposed new services trench. Correct signing & guarding implemented as per TMP. <p>The actual width of the trench depends on the following factors:</p> <ul style="list-style-type: none"> Type and size of services being laid. Number of services being laid in the same trench. If low—and high-voltage cables are laid in the same trench, the effect on the cable ratings must be considered. Whether ducts are being used. If mechanical means are used to excavate the trench to install a single cable, the width can be as narrow as 150mm. The trench width must also allow for mechanical compaction. <p>Trenches should: -</p> <ul style="list-style-type: none"> Be as straight as possible. Where bends are unavoidable, the trench should allow the service to be installed at not less than its minimum bending radius. It should be to the approved dimensions and normally have vertical sides, which should have a side support system (e.g. timbering) if the ground is soft or loose. Have a firm and smooth contoured base. The trench shall be cleared of water by pumping to prevent the risk of collapse and a hazard to the general public, especially trespassing
-------------	---	---

- children. In areas where flooding can occur, measures shall be taken to divert rainwater away from the trench (e.g., by using sandbags).
- Have provisions made during their excavation to cater for persons and vehicles to access the properties and places alongside the route.
- In concrete surfaces, cut through the concrete as per the HAUC

Specification for the Reinstatement of Openings in Highways.

When machines are being used for excavation and the location of the other plant is known, the plant should be uncovered by hand excavation to reduce the possibility of damage. If the excavation is likely to reduce the stability of any part of any structure, work shall not be commenced unless adequate precautions are taken to prevent the structure from collapsing or deteriorating. Flooding or vibration from heavy traffic can cause trench sides to collapse and adjacent structures to subside. A trench-side support system, or shoring, shall be used to prevent this.

Where service trenches are to be left open at any time, MGF Walksafe or a similar device will be installed and maintained to provide safe access to plots.



When machines are used for excavation and the location of the other plant is known, the plant should be uncovered by hand excavation to reduce the risk of damage. If the excavation is likely to reduce the stability of any part of any structure, work shall not be commenced unless adequate precautions are taken to prevent the structure from collapsing or deteriorating. Flooding or vibration from heavy traffic can cause trench sides to collapse and adjacent structures to subside. A trench-side support system, or shoring, shall be used to prevent this.

Excavating service trench

Excavation

All excavation works will be carried out in accordance with the Construction (Design and Management) Regulations 2015, the Guidance contained in Health and Safety in Excavations HS(G) 185 "Be Safe and Shore," and the CIRIA Guide to Trenching Practice.

Before excavation, a Permit to Dig must be raised, an existing utility drawing must be on site, and the excavation area must be scanned using Cat & Genny.

- Each drainage run opened at any one time will not exceed 50m. Where practicable, we will backfill excavations overnight. If excavations are left open, they will be physically barriered off. The foreman will check the face of the excavation before the start of the shift. Any excavation will be checked after events such as heavy rain that might affect its stability. The checks will follow Houlihan & Co.'s checklist. All inspections will be recorded in the Houlihan Record book.

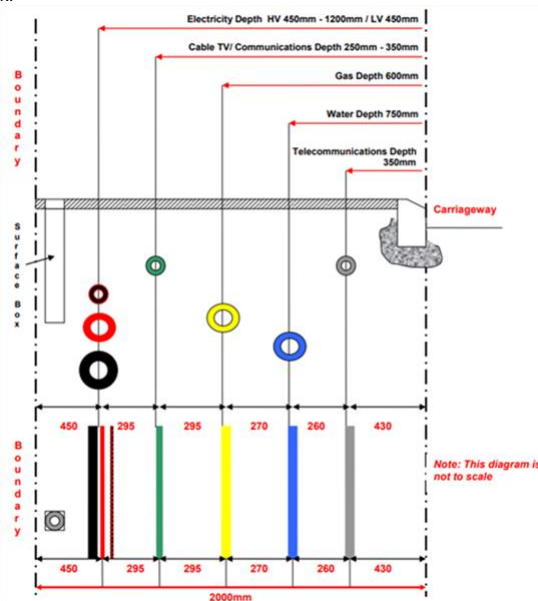

		<ul style="list-style-type: none"> Apparatus must be installed below the carriageway construction layers unless special arrangements have been made with the relevant authorities. Where the plant can only be laid in the road, adequate protection should be provided. Ducts will be laid to specifications, sanded, and warning tape will be placed over them. Pre-tender information and the Construction Phase Plan will be used and considered in light of additional information from utilities' plan drawings, section drawings from utility companies recording the depth of services, and commissioned ground probing radar surveys as necessary. The assumption that live working can be avoided as the default position is set out above, and a full justification of any live working must be set out before this is considered. A method statement for live working will be required as live working is not considered to be properly controlled by any permit-to-work system. HSG47 states, "Where new services such as electrical or gas supplies are being installed, it may be possible to reduce risks by not installing or commissioning them until other groundworks and work on the installation have been completed. This should be considered early in the design process to allow the works to be sequenced accordingly." A cable avoidance tool in conjunction with a transmitter will be used by a competent person prior to the commencement and during any work to identify all services capable of being identified. The intention will be to bring existing service records up to date and to supplement them where they are deficient. Services found will be clearly identified to avoid the risk of damage, and where necessary, we will hand dig around them to expose the services prior to full excavation. Hand digging will require the use of air picks to expose services, starting immediately under the hardcover. Record drawings will be red-lined to show the most up-to-date information, held on site for consultation, and details communicated during inductions, toolbox talks, and in careful briefing on site prior to excavation. If any service is exposed, it will be photographed and sketched with offset notes to inform future re-visits. The backfill will be with self-compacting granular material to a level where compaction is acceptable and then in a suitable material, including selected as dug, which must be possible to excavate with the air pick in the future: i.e., dense, cohesive material like clay must NOT be used. If suitable backfill material is unavailable, the excavation should not proceed. Warning tape will always be placed, and if the utility has not provided it, we will have rolls to use. In addition to using marker tape provided for each service, another physical barrier will be placed on top of the sand. As agreed by management, half the width of the red debris net will be placed first before the backfill. If the physical protection specified is not in place, then the backfill will not be completed until the protection is in place. Great care will be taken to establish what is meant by "terminations" or "diversions", and any assertion that there are "no" services will be treated with caution. Techniques using ground penetrating radar will be considered where information is clearly deficient and services are congested. We will comply with the Permit to Dig system. Traffic management will set up traffic control in stages throughout the entire route to keep disruption to a minimum. The operatives will always barrier the work area to keep the general public safe. The trench to be excavated will be cat and genny to mark up all existing services, and all appropriate drawings will be read. If in any doubt, a trial hole will be hand excavated to confirm any existing services. The trench will be marked out in the footpath or verge so the tarmac or turf can be removed, so the service trench can be excavated to allow the installation of the service main. All arising is to be removed from the site by use of a forward tipping dumper for reuse or removal from the site at a later date, as per the SWMP. Water mains, gas mains and LV electricity cables will be laid by others, into the trench at the correct depth and surrounded with sand or a similar bedding material. Warning tape will be installed and pegged. We will then fill the remainder of the trench with 6F2 or similar and compact it layers to the underside of the new tarmac reinstatement. The trench will be reinstated to the HAUC spec. Once the services are laid, installation records will be taken, and the GPS positions of the services will be noted on the site drawing for the as-installed records. On completion of the works, the traffic management and site equipment will be removed, and any surplus materials and rubbish will be removed from the area. <p>Install services crossovers (Proposed)</p> <ul style="list-style-type: none"> Services positions are per the combined services drawing and must be considered when placing the carriageway. All ducting under the carriageway must be to UKPN standards of 125mm. <div style="text-align: center;">  </div> <ul style="list-style-type: none"> 125ømm and 150ømm Ridgiduct Power HV class 1 ducts fully comply with the electrical supply industry specification for cable protection, ENATS 12-24.
--	--	---



16.0	<p><u>Method of work</u></p> <p>Works on/near Underground Services</p>	<ul style="list-style-type: none"> Contract Manager and Site Supervisor to assess the works and identify the hazards and control measures that need to be put in place to avoid the exposure or to minimise the risk to a reasonably acceptable level. They will be responsible for selecting the correct equipment for the task and the personnel trained to carry out the task. A Task Activity Briefing must be held with the team carrying out the Task, and they must be briefed on the hazards identified, control measures that will be applied, plant and equipment used, work package plan, detailed drawing, and every member of the team must understand and sign the briefing sheet. Work must stop when the weather conditions or any other circumstances change. The risks must be assessed and control measures applied to mitigate these risks before work commences. <p>Refer to</p> <p>RA_26 Work Near Underground Services RA_12 Excavations / Trenches RA_11 Operating 306° Excavators RA_10 Operating Forward Tipping Dumpers</p> <ul style="list-style-type: none"> Pre-tender information and the Construction Phase Plan will be used and considered in light of additional information from utilities' plan drawings, section drawings from utility companies recording depth of services and commissioned ground probing radar surveys as necessary. Any on-site service disconnections should be confirmed by Persimmons prior to the commencement of construction. It is not clear if the proposed disconnections to the cottages have taken place. We will assume they have not happened until we can see proof otherwise. The assumption that live working can be avoided as the default position is set out above, and a full justification of any live working must be set out before this is considered. A method statement for live working will be required, as live working is not considered properly controlled by any permit-to-work system. HSG47, rev. Feb.2014, states "Where new services such as electrical or gas supplies are being installed, it may be possible to reduce risks by not installing or commissioning them until other groundworks and work on the installation have been completed. This should be considered early in the design process to allow the works to be sequenced accordingly." Permit to Dig will be completed prior to excavating on/near underground services, and this will be accompanied by existing and as-built services drawings. Team working on/near underground services will be trained on "Digging on/ near Underground Services" Houlihan's Procedures and will be briefed on the task, provided with existing and/or as-built drawings, and will sign the Permit to Dig prior to starting any works. A cable avoidance tool in conjunction with a transmitter will be used by a competent person, prior to the commencement and during any work, to identify all services and ducts. The intention will be to bring up-to-date records of existing services and to supplement these records where they are deficient. Services found will be clearly identified to avoid the risk of damage, and where necessary, we will hand dig around them to expose the services prior to full excavation. Hand digging will require the use of air picks to expose services, starting immediately under the hard cover. Record drawings will be red-lined to show the most up-to-date information, held available on site for consultation and details communicated at inductions, toolbox talks and in careful briefing on site prior to excavation. As each service is exposed, it will be photographed and sketched with offsets noted to inform future re-visits. Backfill will be with self-compacting granular material to a level where compaction is acceptable and then in suitable material, including selected as dug, which must be possible to excavate with the air pick in future: i.e. dense cohesive material like clay must NOT be used. If suitable backfill material as described is not available, the excavation should not proceed. Warning tape will always be placed on top of the sand backfill, and if it has not been provided by the utility, we will have rolls to use. If physical protection is specified, then the backfill will not be completed until the protection is in place. A 1-tonne bag of sand will be placed at each planned service connection. Red debris netting will be placed over the sand backfill as an additional warning. Great care will be taken to establish what is meant by "terminations" or "diversions", and any assertion that there are "no" services will be treated with caution. Techniques using ground penetrating radar will be considered where information is clearly deficient, and services are congested. We will comply with the Principal Contractor's Permit to Dig system. We will also follow HSE advice that work on or near live services cannot be adequately controlled by a permit-to-work system. We will provide a full method statement for the work and brief our competent team.
------	--	--

17.0	<p><u>Method of work</u></p> <p>Spoil Heaps</p>	<ul style="list-style-type: none"> Contract Manager and Site Supervisor to assess the works and identify the hazards and control measures that need to be put in place to avoid the exposure or to minimise the risk to a reasonably acceptable level. They will be responsible for selecting the correct equipment for the task and the personnel trained to carry out the task. A Task Activity Briefing must be held with the team carrying out the Task, and they must be briefed on the hazards identified, control measures that will be applied, plant and equipment used, work package plan, detailed drawing, and every member of the team must understand and sign the briefing sheet. Work must stop when the weather conditions or any other circumstances change. The risks must be assessed and control measures applied to mitigate these risks before work commences. <p>Refer to</p> <p>RA_11 Operating 306° Excavators RA_10 Operating Forward Tipping Dumpers Installing the Spoil to the TW design</p> <p><u>There will be a need to stockpile separately different categories of material, whether it eventually goes to landfill or can be recycled or reused.</u></p> <ul style="list-style-type: none"> Stockpiles will be constructed by the dumper tipping material at ground level for an excavator to place as a graded pile. The excavator is required to grade off the sides to a compacted batter, throwing off rainwater, and dressing the top likewise. Dumpers must not tip on uneven ground: all tipping operations must be undertaken on level, firm ground. The sides and end of the spoil heap must be bunded (at least 1.0m(H)1.0m(W))
------	---	--

- The stockpile will be monitored for slippage and damped down if any dust becomes airborne.
- The angle of repose will be estimated for different materials, with 45° as an accepted average unless there is evidence of slippage.
- Stockpiles of topsoil will be no higher than 2.0m, as this would prevent aerobic action in the heap and render the topsoil sterile.
- Notify the H&S department to arrange an inspection within 24 hours of the formed spoil heap.
- We will include spoil heaps in our temporary works register, but the detailed construction of the spoil heap will be determined from the material it consists of. Note: any characterisation of material site won is an approximation or average, and a 45° batter has been a proven average, approximate solution. There is no way of removing uncertainty completely in creating spoil heaps, but the experience of our site supervisors practically succeeds. We will provide details in our temporary works register, with risk and category, before creating a stockpile
- If there is a need to place contaminated material in a spoil heap, awaiting the results of tests or grading, for example, it will be placed on thick polythene on hard standing while it remains available. The heap will be graded, sealed, and polythene will be placed over it and weighted down.
- The Company procedure for forming stockpiles will accompany this MS.

Standard detail below:

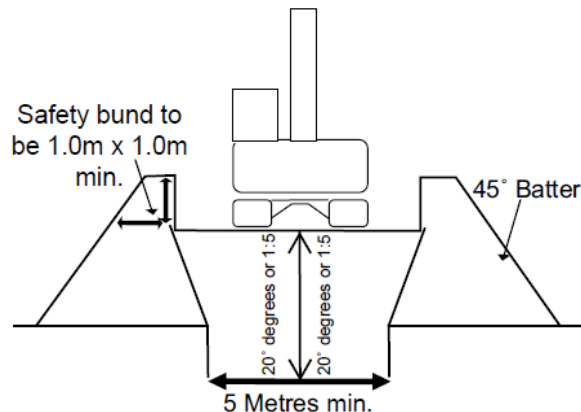

Spoil Heap Removal

- A single excavator will be used for the spoil heap removal.
- The excavator will be used to remove spoil from the heap, dragging it down from higher levels to the loading area.
- The excavator will work from a platform cut into the spoil heap as depicted in the sketch below.

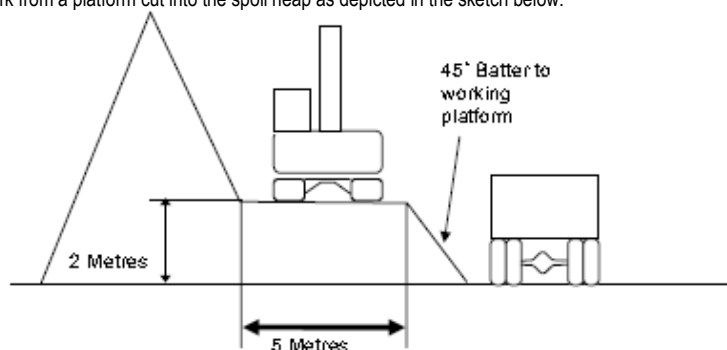

- The working platform must be cut from the spoil heap above and compacted down with the back of the bucket to form a secure and stable working area.
- The platform must not be higher than two metres and must be a minimum of 5 metres wide.
- The machine must not work closer than a metre from the edge of the platform.
- The front of the platform must be battered back at a 45-degree angle at all times.
- The working platform must extend the length of the spoil heap face that is being cut away with an access ramp onto the platform at both ends.
- When tracking the excavator, the operator must always face the direction of travel. When slewing around to face the direction of travel, he must be mindful of any lorries in close proximity to his position.
- The loading area will be a restricted area with no pedestrians allowed into this area. All drivers are to stay in their vehicles at all times while waiting to be loaded.
- While loading the vehicles, the excavator will face the vehicles with the tracks pointing towards the vehicles. This will increase the stability, and the driver will have better visibility while loading the vehicles.

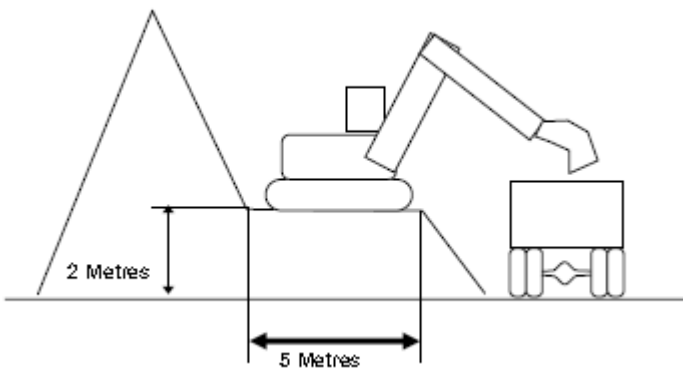

- This process will continue until the spoil heaps are removed down to existing ground levels.
- All vehicular movements are to be monitored and supervised by the machine driver. He will signal when the next lorry is to come forward into the loading area. The loading area is large enough for the lorries to turn and reverse into position if necessary.
- There are no areas with a restricted view, and as only one lorry will be reversing at a time, a banksman is not required at this point.
- Where required and as necessary, continual watering down procedures will be maintained throughout the progress of the work contributing to the suppression of dust migration.

18.0 Method of work

Lifting with excavators

All lifting operations on site should be planned to ensure that they can be carried out safely and that all foreseeable risks have been taken into account.

Poor planning is one of the major causes of accidents arising from the use of excavators for lifting operations.

LOLER requires that the siting, setting up, and use of an excavator for lifting operations be carefully planned so that these activities can be carried out safely and efficiently. The responsibility for planning lifting operations lies with the employer who is undertaking the task. The employer should ensure that they identify one person with sufficient training, practical and theoretical knowledge, and experience, who should be appointed to be responsible for planning and supervising the tasks. This person is known as the "Appointed Person" to BS 7121. – Alban Shehu 07584809221.

To enable lifts to be planned, supervised and carried out effectively, three categories of lifts are detailed below. The category into which a particular lift will fall depends on the assessment of the hazards associated with both the environment in which the lift is to be carried out and those associated with the load and lifting equipment. As can be seen from the table below, increases in either or both environmental or load complexity (the "Complexity Index") will lead to the lift being allocated a higher category. Having identified the hazards associated with a particular lift, a hierarchy of control measures should be applied to eliminate or control those hazards.

Lift categories (Basic / Intermediate / Complex).

Environmental complexity (E)	Lift category		
	Basic	Intermediate	Complex
3	Complex	Complex	Complex
2	Intermediate	Intermediate	Complex
1	Basic	Intermediate	Complex
	1	2	3

Load complexity (L)

Complexity variables and constants	Lift category		
	Basic	Intermediate	Complex
Increasing environmental complexity	The excavator operator has clear sight of the load path and the load is to be placed on the ground.	The load is to be placed over an obstruction such that the excavator operator might not have clear sight of the landing area from the control position.	The load is to be placed in a trench behind a bund, without line of sight, and with proximity hazards, such as scaffolding or overhead power lines.
Constant low load complexity	A load of known weight with designated top lifting points and central centre of gravity. The load does not contain fluids, is not fragile and is inherently stable when landed.	A load of known weight with designated top lifting points and central centre of gravity. The load does not contain fluids, is not fragile and is inherently stable when landed.	A load of known weight with designated top lifting points and central centre of gravity. The load does not contain fluids, is not fragile and is inherently stable when landed.
	Complexity Index E1:L1	Complexity Index E2:L1	Complexity Index E3:L1
Increasing load complexity	A load of known weight with designated top lifting points and central centre of gravity. The load does not contain fluids, is not fragile and is inherently stable when landed.	A load of estimated weight with an estimated centre of gravity and without designated lifting points. The load does not contain fluids, is not fragile and is inherently stable when landed.	A load of estimated weight and centre of gravity and without designated lifting points. The load contains fluids, is fragile and is not stable when landed.
Constant low environmental capacity	The excavator operator has clear sight of the load path and the load is lifted to and from the ground.	The excavator operator has clear sight of the load path and the load is lifted to and from the ground.	The excavator operator has clear sight of the load path and the load is lifted to and from the ground.
	Complexity Index E1:L1	Complexity Index E1:L2	Complexity Index E1:L3

** Only basic lifts can be undertaken in the absence of a formal lift plan produced by the Company's appointed person, providing the criteria below are met.*

Planning, Supervisory and Operating Personnel

The Lifting Team

All lifting operations should be carried out by the lifting team. The team will consist of persons carrying out the following roles:

- Appointed Person
- Lift Supervisor
- Excavator operator
- Slinger/Signaller

The exact team structure will depend on the complexity and size of the job, but all roles must be allocated and duties discharged.

Roles and Responsibilities

Appointed Person

- Planning the lifting operation for Intermediate & complex tasks; selection of the lifting equipment and lifting accessories. Instruction, supervision,

		<p>and consultation with other responsible bodies to ensure effective collaboration as is necessary for the work to be undertaken safely.</p> <ul style="list-style-type: none"> • Ensuring that the outcomes of the planning process are recorded in a lift plan. • Ensuring that adequate pre-operational checks, intermediate inspections, maintenance and thorough examination of the equipment have been carried out. • Ensuring that there is an effective procedure for reporting defects and incidents and for taking any necessary corrective action. • Taking responsibility for the organisation and control of the lifting operation. • Ensuring that the Lift Supervisor and other lifting team members are competent to carry out their roles and are fully briefed on the lift plan's contents, scope and limits. • Being familiar with the relevant parts of the project health and safety plan where the lifting operation is being carried out on a site where the Construction (Design and Management) Regulations 2015 apply. • Liaising effectively with the site temporary works coordinator regarding relevant issues such as ground stability. <p>NOTE: The Appointed Person should have the required understanding and experience in planning lifting operations with excavators.</p> <p><u>Lift Supervisor</u></p> <ul style="list-style-type: none"> • All lifting operations should be supervised by a Lift Supervisor. This role may be combined with that of a slinger signaller for basic lifts, while a separate person will be required for more complex lifts. <p>NOTE: The degree of supervision required will depend on the category of lift and the outcomes of the risk assessment</p> <ul style="list-style-type: none"> • The Lift Supervisor should direct and supervise the lifting operation, ensuring that it is carried out in accordance with the lift plan. The Lift Supervisor should be competent, suitably trained, and have sufficient experience to carry out all relevant duties. <p>NOTE: Competence requirements for self-supervision might differ from those for supervising others.</p> <ul style="list-style-type: none"> • The Lift Supervisor should also have sufficient authority to stop the lifting operation if they consider it dangerous to proceed. <p>NOTE: The Appointed Person may decide to undertake the Lift Supervisor's duties or delegate these to another person with appropriate expertise for the lifting operation.</p> <p><u>Excavator Operator</u></p> <ul style="list-style-type: none"> • The excavator operator should be responsible for the correct operation of the excavator in accordance with the manufacturer's instructions and within the safe system of work, as detailed in the lift plan. • The excavator operator should respond only to the signals from the slinger/ signaller, who should be clearly identified. • The excavator operator should: • Have the necessary competence (skills, knowledge and experience) to carry out lifting operations. • Be familiar with the excavator to be operated. Check that it is in good condition and that it has sufficient capacity to carry out the lift safely. • Ensure that they do not wear loose clothing, which could snag on the controls and lead to unintended movement. • Ensure that the bucket is removed from the machine before the lifting operation starts if the lifting attachment (hook) is fitted to the quick hitch or dipper end. • Ensure that lifting operations are only carried out with the excavator in lifting mode and the overload warning device or rated capacity indicator/limiter selected. • Ensure that they have been briefed on and understand the lift plan (for Intermediate and complex lifts). • Identify the other members of the lifting team and ensure that they are clear of the excavator's arc before operating the machine. • Check that the area where the excavator is to be positioned for the lifting operation is suitable for the task, the landing area is suitable to take the load, the area is segregated from the rest of the site and that only those personnel directly involved in the lift are within the segregated area. • Ensure that the pre-use checks of the lifting accessories to be used have been carried out and that the lifting accessories have been correctly attached to the excavator's lifting attachment. • Ensure that the excavator's control isolator (the dead man lever) is selected when the lifting accessories and load are being attached to avoid unintended movement. • Only follow signals from the designated slinger-signaller during the lifting operation, using the pre-arranged system of signals. <p>NOTE: It is essential that the excavator operator responds immediately to an emergency stop signal from any person.</p> <p><u>Slinger-signaller</u></p> <p>The slinger-signaller should be properly trained in all aspects of slinging loads and signalling and be authorised by the Appointed Person – for intermediate and complex tasks.</p> <p>The slinger-signaller should be responsible for:</p> <ul style="list-style-type: none"> • Carrying out pre-use and post-use checks of lifting accessories. • Attaching and detaching the load to and from the excavator load-lifting attachment. • Using the correct lifting accessories and other equipment in accordance with the lift plan (for intermediate & complex tasks); • Initiating and directing the safe movement of the excavator using a pre-arranged system of signals. If there is more than one slinger-signaller, only one of them should have this responsibility at any one time, depending on their position relative to the excavator. • Guiding movements of the excavator during pick and carry lifting operations. • Ensuring that they are readily identifiable as the designated Slinger/Signaller by the excavator operator. • Movement of the excavator includes pick and carry duties. All pick and carry duties will be continuously controlled by a banksman. <p>NOTE: Where continuity of signalling is required and this slinger-signaller is not visible to the excavator operator, another slinger-signaller or signaller will be necessary to relay signals to the excavator operator. Alternatively, other audio or visual methods may be used. A typical example of audio methods used is where a Slinger/Signaller using a radio continuously instructs the operator to lower a load, e.g. by saying "Lower...lower...lower...", and failure of this continuous instruction from the slinger-signaller indicates that the operator needs to halt all excavator movements.</p> <p>Lift plans will be in the excavator cabs.</p>
--	--	---

19.0	Method of work Work in Confined Spaces	<ul style="list-style-type: none"> Contract Manager and Site Supervisor to assess the works and identify the hazards and control measures that need to be put in place to avoid the exposure or to minimise the risk to a reasonably acceptable level. They will be responsible for selecting the correct equipment for the task and the personnel trained to carry out the task. A Task Activity Briefing must be held with the team carrying out the Task, and they must be briefed on the hazards identified, control measures that will be applied, plant and equipment used, work package plan, detailed drawing, and every member of the team must understand and sign the briefing sheet. Work must stop when the weather conditions or any other circumstances change. The risks must be assessed and control measures applied to mitigate these risks before work commences. <p>Refer to RA_08 Working in Confined Space</p> <p>We will avoid the creation of confined spaces where possible: for example, benching will be done when the first manhole ring is placed.</p> <ul style="list-style-type: none"> A confined space is defined by the presence or absence of prescribed risks. It is possible but unusual for these risks to be present at excavations for foundations or drainage, or for these risks to be reasonably foreseeable. The most common confined space encountered is a manhole connected to a live sewer. All such manholes encountered on this site will be treated as confined spaces. Prior to entering any existing manhole, gas monitoring equipment (which will be kept on site at all times) will be used to determine that it is safe to enter the manhole. The gas monitor will be in use all the time operatives are inside any existing manholes or excavations where it is reasonably foreseeable that the confined space procedures may be necessary. This can be determined by site investigation reports, olfactory smell, visual contaminants, or recommended as a precautionary measure by geotechnical consultants. NOTE: This will be a specific requirement to address a foreseen risk, for example the presence of PAHs. In that case, a gas monitor would have to be specifically calibrated to detect a marker for PAHs, benzo-A-pyrene. The gas monitors used on site will be calibrated to methane/ carbon monoxide and hydrogen sulphide (dual toxic)/ oxygen 19%-23%/ /hydrogen sulphide, and carbon dioxide. TPHs/ PAHs can be discovered by sight and smell. If there is a hostile environment in the confined space, no entry will be attempted. If it is essential to enter, entry will be made by a specialist contractor, using self-contained breathing apparatus or air lines. The contractor we use for specialist entry and accompaniment is ESS Safeforce. Safety harnesses and a tripod will be on site and will be used by the surface rescue trained operatives where a confined space is to be entered vertically. If the confined space involves working away from a vertical access point, a harness is not acceptable, and the operative would have to be accompanied by a specialist team or a rescue entry to bring a rescue stretcher into use would be required.. Escape B.A., which is good for 10 minutes, will be held at the workface, and operatives will be harnessed while in the confined space. Extraction will be by the topman operating the overhead winch attached to the harness. Should entry to the confined space be necessary, only the trained topman will enter using a 30-minute rescue B.A. The tripod is suitable for manhole entry. The gantry will span excavations up to 5.0m in width. Davit arms are suitable for fixing on shoring apparatus. Where working away from vertically under the rescue apparatus, rescue will be by rescue stretcher, which requires entry by trained rescue operatives. If a problem should arise, the emergency services are to be summoned immediately on a 999 call. If anyone has been trapped for more than 5 minutes, they will not be released until paramedics are present to deal with possible toxic shock. Under no circumstances is anyone else to enter a manhole where an incident has occurred other than the competent person/s who have been trained to use the rescue equipment and have completed their training to work in confined spaces. Any operative who engages in work within deep excavations or confined space entry must be trained and certificated for work in Confined Spaces, including rescue. A confined space entry permit will be issued confirming control measures are in place for each day maximum or for each configuration of work. Any changes in support or rescue arrangements will require a new permit. The foreman will control this by issuing, discharging, revising, and ensuring the procedure applies. There will be some confined space entry required, though most is avoidable.
-------------	---	--

20.0	Health & Safety	<ul style="list-style-type: none"> All operators and personnel shall be trained and certified in the functions and role suitable to their responsibility on the site. Approved method statements are to be used together with site rules and restrictions to inform and advise the workforce of the manner in which the operations will be conducted. PPE appropriate to the scheme will be issued on commencement and the operatives and site management are to ensure the correct and continued use of such whilst on site. All items of plant, access and lifting equipment are to have been inspected prior to delivery and be accompanied by the required documentation. Site checks will be performed to the manufacturer's / supplier's recommendations. Where appropriate, Operatives will be trained for Confined Space Work. Works contained in or about live sewers are to be tested for the presence of gas and are to employ additional PPE of gauntlets, enclosure suits / overalls, breathing equipment and tripod / harness / winch. Gas monitoring equipment is to be used throughout such operations. If it is not possible to Step or batter the Excavations Earthwork support is to be used in all excavations over 1.2m deep and at any other time as is deemed necessary. Manual handling to be kept to a minimum, with nothing larger than 25 Kg without a suitable risk assessment. Banksmen are to attend all machine excavations, lifting operations, especially all pick and carry duties, and direct site traffic as required. Eye and ear protection is required when using powered tools. All users of abrasive wheels must be abrasive wheel awareness trained & face-fit tested. Site dump trucks etc. are to be fitted with ROPS, seat belts & reversing warning indicators.
-------------	-----------------	---

	<ul style="list-style-type: none"> Existing site services are to be identified located [using scanners] and protected throughout the works and shall only be exposed by means of hand excavations to determine depths etc. Main traffic routes are to be established for bulk removal or transportation of materials. Small tools will be kept in the storage container when not in use. Plant is to be left in-situ on site but will be secured and immobilised. All small drum oils to be kept in COSHH store. <p>Welfare Arrangements</p> <ul style="list-style-type: none"> Dandara Homes has provided adequate welfare provision. The team will use the main compound on Drewer Way until the site / Phase 4 B compound is constructed. <p>Personal Protective Equipment</p> <ul style="list-style-type: none"> Basic PPE for our groundworkers has been assessed to be boots, hi-vis jackets, helmets at all times. Gloves, helmet mounted ear defenders, wellington boots and eye protection are available on site depending on the task in hand. We have a mandatory glove policy, following a glove selection procedure, based on risk assessment. Glove selection policy attached. <ul style="list-style-type: none"> Safety helmets EN 397 High visibility vest/jacket EN 471 Class 2 Safety Gloves EN 388, and see the full glove selection policy Hearing protection EN 352-1/EN 352-2 is mandatory when using breakers, or working in areas where noise levels rise above 85 dB(A). Safety glasses to EN 166-F when placing concrete. Safety goggles to EN 166 B when cutting concrete or steel products. Safety boots to EN 345: S1-P Suitable footwear when standing on concrete, Wellingtons to EN 345 S4 Face shield when using an air pick Vibration procedure attached, which includes assessment nomograms for all handheld vibration-emitting plant Noise assessments are attached for all noise-emitting plant. More specialised equipment for confined spaces, asbestos, and contaminated land will be issued as required by risk assessments from time to time and signed for in a Construction Confederation register compliant with the Construction (Design and Management) Regulations 2015. PPE must still be worn in hot weather: Breaks from work and drinking water are essential, but where risk assessments show the need for PPE, it must be worn, or work halted. Sun block is available on all sites. Sunglasses will be issued on sites where glare is a problem and on all sites where chalk is present. Personal protective equipment is provided free of charge to our employees and will be replaced when required. <p>Bucket changing areas</p> <ul style="list-style-type: none"> Suitable fencing and signage will be erected in close proximity to excavator working areas where buckets will require changing. The designated areas will move to minimise transit but will remain of the same standard even for short-duration work. The smallest changing area must consist of 3 Heras fencing panels and a half-height barrier along the face so all 4 sides are enclosed; the requirement for the half-height barrier is to prevent 10t & below excavators from damaging any hydraulic hoses on the underside the boom or the fencing panel. NOTE: All our quick hitches are fully automatic. <p>Noise Monitoring</p> <p><u>The following working practices will be employed to reduce noise throughout construction activity on site:</u></p> <ul style="list-style-type: none"> Where practicable, position the plant away from site boundaries, particularly on sites with neighbours within close vicinity. Make use of stockpiles as noise shields Arrange delivery times on site to suit the area. Use all silencing equipment available and keep panels closed on all generators and compressors. Switch off noisy equipment when not needed. Arrange traffic routes for mobile plant so the amount of reversing required is minimised, reducing the use of reverse warning beepers. If there is doubt as to noise levels or complaints, we will deploy a Class 1 noise level meter for operations. Environmental noise measurement has been by a specialist. There is no Sec.60/61 in place. Observe restrictions on working hours: No plant operating before 8:00 am We have assessed the noise levels for all our plant- see attached.. <p>Dust Monitoring</p> <ul style="list-style-type: none"> Routine visual monitoring will be undertaken for dust at all operational areas at the site. If significant visual dust is observed at the boundaries of the operational areas, action will be taken to suppress it. We won't wait for the dust to settle; we'll also respond if it is seen between regular preventive road cleaning and dust suppression with a bowser. The most useful stipulation, if we have bulk shifting of waste over haul roads, is that the exhaust vents upwards, not down at the road. If haul roads were tarmacked, this would massively reduce the problem. <p>This action would comprise the application of water to waste stockpiles, roads, and waste treatment activities as appropriate. Inspections will be carried out by site operatives throughout the day and by the Site Manager daily.</p> <p>Refuelling Area</p> <ul style="list-style-type: none"> During the fuelling process, a drip tray will be positioned under the connection point to ensure that any drips of diesel are caught in the tray; the same process applies to filling petrol tools/cans, etc. If the hose has been contained within the secondary bund and submersed in diesel, the hose itself must be located within the drip tray; take the lid off if necessary. A fire point with 2 no. CO2 extinguishers will be placed close to the refuelling area, appropriately signed. <p>Storage of tools & materials</p> <ul style="list-style-type: none"> Small tools will be kept in the storage container when not in use. The plant is to be left in situ on site, but will be secured and immobilised. All small drum oils are to be kept in the CoSHH store. Materials that are on pallets will not be stacked more than two pallets high. Lightweight materials such as cellcore, cordek, and polystyrene panels used for floors will be weighted down. <p>Interface with other trades</p>
--	---

- Coordinating work with other trades.
- From the arrival of other trades on site, work will be coordinated by our Site foreman
- Our works will be segregated from other trades.
- Excavations will be guarded to prevent unauthorised access. We will not undermine scaffolding at later stages of the job and will not work underneath scaffolding. Our machinery has flashing hazard lights, and all reversing will be kept to a minimum.
- Note that flashing lights interfere with laser levels. Manufacturers have found no way around this problem. So lights should be switched off when the laser level is in use, but only in the area our site engineer defines as where interference could occur. This is not a blanket excuse for the whole site.

Housekeeping

- Materials will only be stored in designated areas. Work areas will be cleared of waste as soon as practical, including materials surplus to a task. If this does not happen in a timely fashion, the working area will become constricted, and separation will become difficult. If we leave behind waste or surplus materials, this makes distancing difficult for others. We should require this of other trades before we enter a new work area.
- Any waste materials are to be disposed of in the appropriate skip.
- Waste from disposal bins around the site, including in offices, must be removed on a regular basis during the day.
- Clear access at all times must be maintained should the emergency services be required.

Reporting of Accidents

- Any accidents whatsoever arising out of or in connection with the site works on or off Site which cause personal injury, property damage shall be reported to the OHSEQ department immediately, in writing giving full details and statements of witnesses. In the event of a reportable accident the Health & Safety Executive shall be informed and an F2508 submitted.
- All accidents to be recorded in the Accident Book and reported to the Client.
- All near misses will be reported to the Client.
- If CPR is required, then the following guidelines have been extracted from the latest Resuscitation Council UK Statement on COVID-19 in relation to CPR and resuscitation:
 - Because of the heightened awareness of the possibility that the victim may have COVID-19, the Resuscitation Council UK offers this advice:
 - Recognise cardiac arrest by looking for the absence of signs of life and the absence of normal breathing. Do not listen or feel for breathing by placing your ear and cheek close to the patient's mouth. If you are in any doubt about confirming cardiac arrest, the default position is to start chest compressions until help arrives.
 - Make sure an ambulance is on its way.
 - If there is a perceived risk of infection, rescuers should place a cloth/towel over the victim's mouth and nose and attempt compression-only CPR and early defibrillation until the ambulance (or advanced care team) arrives. Put your hands together in the middle of the chest and push hard and fast.
 - Early use of a defibrillator significantly increases the person's chances of survival and does not increase the risk of infection.
 - If the rescuer has access to personal protective equipment (PPE) (e.g. face mask, disposable gloves, eye protection), these should be worn.
 - After performing compression-only CPR, all rescuers should wash their hands thoroughly with soap and water; alcohol-based hand gel is a convenient alternative. They should also seek advice from the NHS 111 coronavirus advice service or a medical adviser.

How to do CPR on an adult COVID-19 update

1. If someone is unconscious and not breathing normally, do not put your face near to theirs
2. Call for an ambulance
3. Use a towel or piece of clothing and lay it over the mouth and nose
4. Do not do mouth to mouth
5. Start chest compressions to the tempo of "Staying Alive"
6. Use a Public Access Defibrillator if available.



Source: Resuscitation Council UK

Find out how St John are supporting the NHS with the COVID-19 outbreak at sja.org.uk/COVID-19

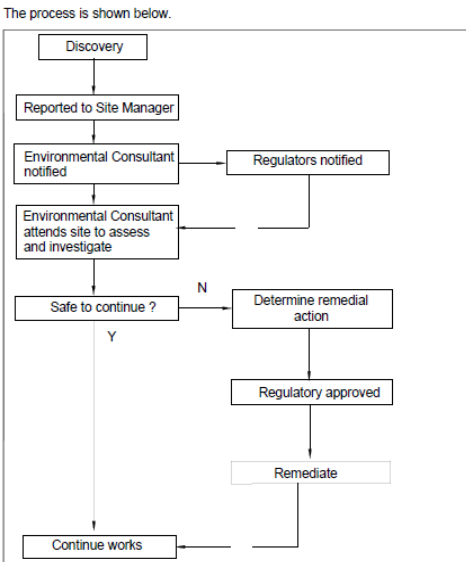

		<ul style="list-style-type: none"> Any accidents whatsoever arising out of or in connection with the site works on or off Site which cause personal injury, property damage shall be reported to the OHSEQ department immediately, in writing, giving full details and statements of witnesses. In the event of a reportable accident, the Health & Safety Executive shall be informed and an F2508 submitted. All accidents to be recorded in the Accident Book and reported to the Client. All near misses will be reported to the Client /Principal Contractor. Trained First Aider, Jason Barrowman, will be responsible for all on-site treatment to operatives. First Aid equipment and facilities shall be available in the Houlihan & Co site office H&Co's First Aider will make entries in the Accident Book if the IP does not want to and agrees to the entry.
--	--	--

<p>21.0</p>	<p>Discovery Strategy</p> <p><u>Contamination</u></p>	<p>It remains possible that unexpected soil conditions may be encountered during the process of construction. Examples may include oily pockets within the soil, pockets of cement boarding or fibrous materials within the soil, black ashy materials, soils exhibiting strong odours, brightly coloured materials and former structures or brickwork. Should previously undiscovered contamination be encountered during construction, it should be reported to the Site Manager immediately so that any necessary inspection may be conducted. A watching brief approach is to be adopted during the various phases of the site's development, such that in the event of suspicious conditions or materials being encountered, the Environmental Consultant can attend the site to inspect the 'discovery'. Records should be kept and samples submitted for analysis where conditions encountered are not as anticipated. The results of any such testing should be sent to the Local Authority for consultation. Depending on the type, nature and extent of any such 'discovery', it may be necessary to halt works in that location until such time as the assessment has been completed. This should be reviewed on a 'discovery' specific basis and in conjunction with regulatory consultation.</p> <p>As a general guide, where such unexpected conditions are encountered, the following approach is recommended:</p> <ul style="list-style-type: none"> All discoveries are to be reported to the Site Manager immediately, and work at that location is to halt until further notice. The area should be cordoned off using an appropriate barrier system. The Site Manager is to report any such discoveries to the Client and the Environmental Consultant: Following notification from the Site Manager, the Environmental Consultant shall discuss the discovery with the Local Authority and, if considered necessary, arrange to meet an Officer on site to view the discovery; The Environmental Consultant shall attend the site to record the location, extent and nature of the discovery and implement an appropriate sampling and analysis regime, taking due account of the type and nature of the discovery, known and probable land uses in that area of the site. Where remedial action is required, regulatory consultation and approval will be sought; A record will be produced by the Environmental Consultant and held on site (with copies held by the Environmental Consultant, Client and Local Authority), detailing the discovery, assessment works undertaken, findings thereof, confirmation either of no action required or detailing the remedial action taken and validation thereof.
	<p><u>Waste Disposal</u></p>	<p>The process is shown below.</p>  <pre> graph TD A[Discovery] --> B[Reported to Site Manager] B --> C[Environmental Consultant notified] C --> D[Environmental Consultant attends site to assess and investigate] E[Regulators notified] --> D D --> F{Safe to continue?} F -- Y --> G[Continue works] F -- N --> H[Determine remedial action] H --> I[Regulatory approved] I --> J[Remediate] J --> G </pre>
		<p><u>Duty of Care</u></p> <p>As the persons undertaking construction work and specifying a particular waste disposal carrier and receiver, Houlihan & Co. have a duty of care under the Environmental Protection Act 1990. We must and will take all reasonable measures:</p> <ul style="list-style-type: none"> To prevent any contravention by another person of the legal requirements associated with depositing, treating or keeping of controlled waste or its transport. To prevent the escape of waste from our control or that of any other person.

		<p>On the transfer of waste to ensure that the transfer is only to an authorised person and that a written description of the controlled waste is transferred, which will enable other persons to understand clearly the nature of the waste and comply with the duty to prevent its escape. (An authorised person is a waste collection authority or the holder of a waste management licence.)</p> <p>Keeping Waste Safely</p> <p>To comply with our duty of care, we must ensure that the waste is not affected by:</p> <ul style="list-style-type: none"> • Corrosion or wear of waste containers. • Accidental spillage or leakage. • Accidents or weather breaking the containment of waste and allowing its escape. • Waste blowing away or falling whilst stored or transported. • Scavenging of waste by vandals, thieves, children, trespassers or animals. <p>The site perimeter will be secured and signed. Stockpile areas will be clearly delineated and set on an impervious membrane. Dust will be controlled by damping down or covering.</p> <p>Transferring Waste</p> <p>Waste can only be transferred to an authorised person. The Waste (England and Wales) Regulations 2011 detail the transfer note arrangements. The note must be completed by a responsible person from the company producing the waste, not by the carrier. The responsible person will consider whether the waste will require a special container to prevent its escape (e.g. a closed skip for asbestos) or if the waste can be mixed safely with other waste.</p> <p>Part of the duty of care obligation is that checks are carried out before waste is transferred. Tip licences in particular must be carefully checked to ensure that the tip can receive the type of material being sent. Carriers' original registration certificates, not photocopies, must be carefully inspected. A Waste Transfer Note (WTN) must be completed and signed by both the person handing over the waste and the person receiving it. It must contain enough information about the waste for it to be handled safely and either recovered or disposed of legally.</p> <p>The WTN must include:</p> <ul style="list-style-type: none"> • a description of the waste • any processes the waste has been through • how the waste is contained or packaged • the quantity of the waste • the place, date and time of transfer • the name and address of both parties • details of the permit, licence or exemption of the person receiving the waste • the appropriate European Waste Catalogue (EWC) code for the waste • a declaration that you have applied the waste management hierarchy. • the 2007 Standard Industrial Classification (SIC) code of the person transferring the waste • The producer is most able to describe their waste accurately. It is not acceptable to use non-specific terms such as 'general waste'. • Separate paperwork must be completed for hazardous waste.
<p>22.0</p>	<p><u>Silt Management</u></p>	<p><u>Measures on Enabling Phase and Preparatory Earthworks.</u></p> <ul style="list-style-type: none"> • Stripping topsoil must be done in stages to maintain as much vegetation cover across the site as possible. • Retention of vegetation as far as reasonably practicable along south-western boundaries to promote infiltration of any surface water and silt run-off. • Haul road will be topped with tarmac, easy to clean with a road sweeper. • A jet wash and cattle grid will be installed at the exit of the site to clean the wheels of any vehicle leaving the site. • Designated car park will be topped with stone and will be maintained mud-free. <p><u>Additional Measures during Construction Phase</u></p> <ul style="list-style-type: none"> • The placement of gully protection (specially designed gully guards, or standard protection - straw and terram) in all gullies during construction, which are to be inspected and replaced/cleaned when necessary. • Minimising the movement of plant on and off roads to prevent the tracking of excess soil onto roads and highways. • The installation of hardstanding areas to the front of all plots to enable 'clean' forklift access. • The placement of hardstanding or topsoil at the earliest opportunity to control surface runoff from completed areas. • Avoid tracking on areas of permeable paving once installed and otherwise maintain paving areas. <p><u>Monitoring Procedures and Records</u></p> <ul style="list-style-type: none"> • Inspection of all silt fencing, silt traps and manholes to monitor the discharge entering the drainage system and the sensitive receptors around all site boundaries. • Maintenance, cleaning and replacement of silt fences, silt traps, silt matting, and Terram as required. • The completion of the Environment Checklist (Site Audit form) on a weekly basis, which will assist in documenting any changes on site and identifying any changes needed to the protection systems as the development progresses. • The Site Specific Environmental Action Plan (SSEAP) will be reviewed using the Environmental Checklist and updated when required to reflect changes to site conditions and operations. • All records will be reviewed on a monthly basis. Dandara Environmental Department must be contacted apart from the Health and Safety department of Houlihan & Co in the event of heavy rainfall breaching protective measures.
<p>23.0</p>	<p>COSHH</p>	<p>COSHH Register: refer to the OHSEQ notice board in the site office:</p> <ul style="list-style-type: none"> • AdBlue

		<ul style="list-style-type: none"> • Asphalt Materials • Bituthene Primer • Bituthene Adhesive Primer • Butane - Calor • Cement – packaged • Cement colouring – Sealotone • Diesel • JCB Grease • JCB Hydraulic Fluid • Engine Oil • Marking Paint – Powerline • Mortar Plasticiser – Sealocrete • Petrol • Pipe Joint Lubricant – Hepworth/ Osma • Sika block paving seal • Silica • Weedkiller Doff • Wet Concrete • White spirit
--	--	--

24.0	Immediate Emergency Procedures	<ol style="list-style-type: none"> 1. In case of an accident, Phone 999 and ask for the Emergency Services. 2. Shut Down all Plant and Cordon off the Area. 3. Inform the Main Contractor Site Manager. 4. Contact Agron Selita at 07507430655 5. In case of Fire, follow the Signage and meet at the Assembly point near the front gate:
	Author:	Alban Shehu

Houlihan & Co. (Excavations) Limited OHSEQ Management System



Contract: Dandara, Stortford Road, Great Dunmow.		OPERATION: (Site Specific) Groundworks	
ORIGINATED BY: A. Shehu	DATE: 23/11/2025	APPROVED BY: Conor Gough	RE-ASSESS: At least every 3 months or following an incident or change in working equipment or processes

Risk Rating: Severity (S) & Likelihood (L) as 1 (low), 2 or 3 (high), multiply to give Overall Rating (R) 1 (low) to 9 (high) for priority actions

A=Operative: B=Others on Site, including clients, staff: C=Public

Hazard	People at Risk			Risk Rating			Control Measures STANDARD PPE TO BE WORN ON SITE (HI-VIZ, SAFETY FOOTWEAR, HEAD PROTECTION) ADDITIONAL/ALTERNATIVE PPE TO BE WORN WHEN REQUIRED BY RISK ASSESSMENT	Residual Risk Rating		
	A	B	C	S 1,2,3	L 1,2,3	R 1-9		S 1,2,3	L 1,2,3	R 1-9
All works Leptospirosis	Y	Y	N	2	3	6	<ul style="list-style-type: none"> The likelihood of rats and hence leptospirosis has been made clear to all operatives at their company induction. The main defence against the disease is personal hygiene, including not smoking on site. The HSE information leaflet has been used in toolbox talks and is issued to operatives Prevent/discourage rats from coming onto the site. Ensure adequate pest control provisions are in place around the site and welfare facilities. Do not leave scraps of food lying around to attract them. Ensure a waterproof plaster covers cuts, grazes, and open wounds. Wear waterproof gloves and clothing when working in wet conditions. Wash your hands and arms thoroughly before eating, drinking and smoking. Report any ill health to your Supervisor or Manager. If you start to suffer from what seems like the flu but have reason to believe that it may be leptospirosis, see your doctor as a matter of urgency. Inform your GP of your occupation. The internal/external refuse storage area is regularly cleaned and monitored. All waste bins were kept in a clean condition and emptied on a frequent basis. Non-toxic monitoring bait devices are used for pest control within the food preparation and food storage areas. Visual checks are carried out by employees, and detailed records are maintained when evidence of pest activity has been found, initiating any follow-up action. 	2	1	2
Delivering, unloading, and reloading vehicle on site Mechanical failure, road traffic incident, contact with pedestrians or others.	Y	Y	N	3	3	6	<ul style="list-style-type: none"> Only trained and competent site staff to complete tasks. Staff to follow prescribed safe systems of work detailed under the sub-heading "Plant and vehicle preparation and delivery" of this document. If at any point, the safe systems of work detailed in this document are deemed insufficient, work is to stop, a risk assessment shall be completed and new safe systems of work developed and implemented. All deliveries to be undertaken on-site; within a controlled offloading pre-planned area, not in the public domain. 	3	1	3
Vehicle movements Vehicles, including mobile plant, coming into contact with workers, other plant/vehicles or property resulting in potential serious injury to persons and/or damage to plant/property.	Y	Y	N	3	3	9	<ul style="list-style-type: none"> All site personnel will be made aware of the requirements of the Principal Contractor's traffic management arrangements at the site induction and updated whenever necessary. Vehicle banksman are to be suitably trained. Suitable safety signs will be displayed on site instructing drivers not to use mobile phones, not to reverse without a banksman and to stop if they cannot see the banksman. The use of mobile phones is not permitted within the processing area. All persons on site, including lorry drivers outside of their cabs are to wear the PPE required by site rules including high visibility vest / coat. All vehicles must travel at a safe speed for the conditions below the site speed limit, which is displayed on site. Within the processing area, 	3	1	3

Prepared by: Agron Selita	Client: Dandara Homes
Page 28 of 49	Doc: M0626 MS 2501 278 Works

RISK ASSESSMENT_25 – Construction Work in Public Highways

Hazard	Consequences	Who is at Risk?	Risk Score			Control Measures	Residual Risk Score		
			S	L	Score		S	L	Score
Working in Live Carriageway (Highway) Vehicle strike operative Vehicle strike plant Plant strike vehicle Vehicle strikes members of the public	Death or Major Injury Damage to plant, vehicles, and property.	Employees, Members of Public Pedestrians Drivers Untrained personnel	5	4	20	<ul style="list-style-type: none"> Traffic management must be planned at an early stage, seeking approval from the local authority, and this could be either under S278, S50 or S184. Signs and Chapter 8 barriers were hired in from a specialist contractor complying with the Safety at Street works CoP. TM initially placed by a specialist contractor from a correctly equipped lorry as per TM approval. All advance warning signs are used as per the TMP. All advance warning signs are clean, suitably weighted and clearly visible. All advance warning signs are placed so as not to obstruct vehicular traffic. A minimum 450mm gap is maintained between the traffic and each advance warning sign. Introduction of speed restriction measures. All operations carried out are done with the operatives facing the oncoming traffic. Using 750mm size signs on all single carriageways to minimise the width of the obstruction. All vehicles are fully compliant for road use. Selection of a plant with minimum tail swing to be used. Ensuring all flashing lights are working and being used. Supervisors and operatives must be either qualified to the relevant NRSWA or working towards the qualification. Use of Class 3 high-visibility clothing compliant with BS EN 471. Ensure longitudinal and lateral safety zones have been installed correctly as per the carriageway speed limit. Do not carry out any maintenance in the safety zones. 	5	1	5
Working around members of the public Plant strikes public Vehicle strikes members of the public. Failure of the plant Misuse of the plant	Death or major injury	Members of Public Especially at risk Children Pedestrian with disabilities Pedestrians accompanying children.	5	4		<ul style="list-style-type: none"> School/rush hours will be avoided, and work will be scheduled for school holidays and weekends if possible. Ensuring TM equipment is not obstructing access/exit points to properties, maintaining access for emergency services. Safe pedestrian access is provided with minimum deviation from the normal route. Ensuring an absolute minimum width of 1.2 m is maintained at all times on footways. Ensuring all signs used for pedestrians are clean and clear. Use verge and/or road for sign placement. Use pedestrian barriers to clearly identify the temporary walkways. Use ramps to aid access and egress. Ramps must be fixed to the ground. Install a temporary pedestrian crossing near the works to eliminate unauthorised crossings. Any excavation left open out of working hours must be secured with Heras fencing. The plant will be banked across the pedestrian crossing. Whenever it is safe and possible, the TM will be brought in and set up the following day to minimise the disruption and eliminate the hazards caused by TM. 	5	1	5
Slips, Trips and Falls Poor Housekeeping standards	Fractures and Sprains as a result of falling.	Employees, Members of Public	3	4	12	<ul style="list-style-type: none"> Always maintain the working zone in good order. Do not store excess materials within the TM zone. Road will be kept clear of mud or debris. All areas accessible to members of the public are to be maintained at all times; no materials or tools are to be left in public areas or safety zones. Any damage caused to any footpaths and highways must be reported, and any remedial action must be carried out without delay. Traffic management will be checked every day and at end of shift and left secure. 	3	1	3

Hazard	Consequences	Who is at Risk?	Risk Score			Control Measures	Residual Risk Score		
			S	L	Score		S	L	Score
<p>Falls from heights from delivery vehicles.</p> <p>Falls of materials from delivery vehicles</p>	<p>Fractures, Sprains and other serious injuries as a result of falling from a delivery vehicle during loading</p>	<p>Employees Members of Public</p>	4	4	16	<ul style="list-style-type: none"> All flatbed delivery to be provided with edge protection. Edge protection to be installed prior to any operative gaining access to the back of delivery vehicles to commence offloading. Lorry loader to be used to access the back of delivery vehicles at all times. Operatives must not climb into dumper skips to offload materials. Loads to be inspected before releasing restraint straps upon arrival at the site. Follow a safe system of work for the release of all load restraints. 	5	1	5
<p>Manual Handling</p> <p>Effects of lifting, movement of materials</p>	<p>Musculoskeletal injuries</p>	<p>Employees</p>	3	3	9	<ul style="list-style-type: none"> All operatives to follow all control measures outlined within the RA Manual Handling Always use mechanical means of lifting if available for unloading and movement of materials. Obtain load weights and centre of gravity before materials are moved manually. When assessing a lift to be carried out manually, supervisors and managers should consider T.I.L.E before completing an individual assessment. All operatives to recognise their capabilities and only lift weights that they are comfortable with. 	3	1	3
<p>Planning and gathering information for identifying the hazards</p>	<p>Problems identified:</p> <ul style="list-style-type: none"> Provision for a compound and welfare unit. Selecting a designated safe storage area for plant and materials. Selecting a safe access route from the storage area to the work area. Selecting a refuelling area. <p>Hierarchy of control measures followed:</p> <ul style="list-style-type: none"> Avoidance of the need to work on the highway by design. Avoid the need for open-cut trenching with trenchless technology. Pedestrian access is unaffected if possible, and a safe direction is on the same side of the road as the first choice. Work scheduled at least during less busy times. <p>Further Guidance on these works is contained in the following: Provision and Use of Work Equipment Regulations 1998, and ACOP Construction (Design and Management) Regulations 2015 New Roads and Street Works Act, 1991 Traffic Signs Regulations and General Directions, 2002 Street Works (Qualifications of Supervisors and Operatives) Regulations 1992 Highways Act 1980 Traffic Management Act 2005.</p> <p>Company Procedures applicable: Safe use of excavators. Excavation Safe use of dumpers Work near underground services Confined space working.</p>								

Risk Matrix Calculation

SEVERITY RATING	
Index	Description
1	No injury, damage, sickness or loss (with no time off)
2	Minor injury or illness, minor damage or loss (and/or up to 7 days off)
3	Reportable injuries or illness, substantial damage or loss (or over 7 days off)
4	Major injury, long-term absence.
5	Fatality, catastrophic damage or loss (death)

Likelihood Rating		
Index	Description	Definition
1	Very Unlikely	Less than once every 10 years
2	Unlikely	Once in every 5 – 10 years
3	Likely	Once in every 2 – 5 years
4	Very likely	Once in every 2 years
5	Certain	More than once per year

L I K E L I H O O D	1	1	2	3	4	5
	2	2	4	6	8	10
	3	3	6	9	12	15
	4	4	8	12	16	20
	5	5	10	15	20	25
			1	2	3	4
SEVERITY						

The following shading indicates the level of risk.	
Very High	16 – 25
High	11 - 15
Medium	6 - 10
Low	1 – 5

Houlihan & Co. (Excavations) Limited

OHSEQ Management System



							the speed limit is 5 mph. <ul style="list-style-type: none"> Access routes on site will be formed with a safe incline, and bunds or barriers will be provided to prevent vehicles from falling into excavations or off ramps. 			
Operating Plant and Equipment Contact between the plant and operatives resulting in possible serious injury. Plant overturning resulting in injury to the operator or other persons Failure of lifting equipment resulting in persons being struck by falling loads/equipment	Y	Y	N	3	3	9	<ul style="list-style-type: none"> Establish a clear work area, cordon off if necessary to prevent pedestrian / unauthorised access. Site management to determine the need for fencing/barriers to ensure operatives not involved in the task do not enter the works area. Operatives must never stand under an excavator bucket or a suspended load. Only authorised competent people are allowed to operate the plant. All plant operators to hold valid qualifications for the category of plant they operate. All machinery to be inspected before use and, where required, to have valid thorough examination certificates. Operators are required to complete and record daily pre-use inspections. The operator must ensure that any defects/damage are reported to H&Co's Site Manager before operating the plant. All mobile plant to have flashing beacons and 360-degree vision ability. Loading shoves to have a reversing audible warning system. Plant to travel at a safe speed for the conditions and always within the site speed limit. Keys are to be removed from the plant, not in use, and safely secured at the end of the shift. The plant is only to be used for the purpose for which it is intended and in conditions for which it is intended. The plant must be banked in areas where pedestrians are present. Access routes on site will be formed with a safe incline, and bunds or barriers will be provided to prevent mobile plant from falling into excavations or off ramps. 	3	1	3
Lifting with site excavators Failing Loads, trapping fingers, Load swing causing injury, falls from height, and Crushing.	Y	Y	N	3	3	9	<ul style="list-style-type: none"> Staff to follow prescribed safe systems of work detailed under the sub-heading "Lifting with excavators" of this document. Loads to be slung by competent operatives. Banksman to ensure that no lifts are taken over the adjacent work area and that all loads are correctly slung. Basic task lifts are to be undertaken without the approval of the company's appointed person. Intermediate & complex tasks require a specific lift plan. No lifting over populated areas. No lifting with bucket attached. Prior to the instruction to lift the slinger signaller to stand clear of the load Keep load as low as possible and use guide ropes on 2 corners where necessary All delivery vehicles to have edge protection fitted. If delivery vehicles have no edge protection - TURN THE LORRY AWAY. All excavator drivers to hold current CPCS cards. being operated Excavators to be thoroughly examined at 12 monthly intervals. All excavators to have daily inspection (F91) to be carried out and recorded by the machine operator All accessories are to be checked prior to use by the slinger signaller. All accessories are to have 6 6-monthly thorough inspections. Slinger signaller to ensure lifting accessories have sufficient SWL IF IN DOUBT CONSULT H&Co's APPOINTED PERSON – ALBAN SHEHU: 07584809221 	3	1	3
Quick Hitch devices on excavators Operatives being crushed by falling buckets, possible fatal or very serious injury.	Y	Y	N	3	2	6	<ul style="list-style-type: none"> Identify the type of quick hitch on each excavator and ensure you know if it requires pins to be fitted. Test that the bucket is correctly attached. (IE Shake, rattle and roll) The machine will be checked regularly. Faults will be reported to the site manager immediately, and the machine will be stood down until repaired. Where required, pins must be fitted after changing the buckets; this is the driver's responsibility, not the nearest operative. Operatives are <u>not</u> to stand underneath buckets at any time. 	3	1	3

Houlihan & Co. (Excavations) Limited

OHSEQ Management System



Work potentially generating dust-vehicle movements on site Inhalation of silica, asbestos, other respirable airborne contaminants, and environmental nuisance	Y	Y	Y	3	2	6	<ul style="list-style-type: none"> • Speed restricted to 5mph. • Lorries to be specified on hire as having upward-directed exhausts. • PC to control forklift movements. • Hard top to roads, haul roads where practicable. • Road cleaning. • Drop distances from bucket into lorry or dumper skip to be minimised. • Traffic marshal to explain routes on site. • Any concrete and tarmac cutting will be carried out using water suppression. • Water bowser will be used when it is required (especially in the summertime) 	3	1	3
Work potentially generating dust-bulk movement of materials Inhalation of silica, an environmental nuisance	Y	Y	Y	3	2	6	<ul style="list-style-type: none"> • Scrape by blade instead of digging and dumper transfer. • Avoid double handling whenever possible. • Cover loads in motion & static spoils on site. • Limit drop distances to a minimum. • Continuous micro spray as new surfaces are exposed on spoil heaps in dry weather. • Use a larger plant to minimise the number of movements. • Retain vegetation until removed just in time. • Road cleaning on and off-site. 	3	1	3
Machine operations Maintenance work on plant- greasing, hydraulic oil leaks, pressurising tracks Oil, and fuel spills.	Y	Y	N	3	2	6	<ul style="list-style-type: none"> • Re-fuelling area. • Environmental procedure for spills and hydraulic hose bursts. • Fluids under pressure, whether toxic or not, carry the risk of serious harm if injected. • Minor entry wound belies harm caused as fluid blocks veins or arteries. • No fault should be traced without Kevlar gloves; only Houlihan-issue grease guns should be used. • Fitters to adjust excavator tracks unless the driver has had training. • Preventive maintenance of machines. • Daily pre-operation inspection checks are carried out & recorded weekly as a minimum. 	3	1	3
Compressor operations Oil, fuel spills.	Y	Y	N	2	2	4	<ul style="list-style-type: none"> • Re-fuelling area. • Environmental procedure for spills and hydraulic hose bursts. • Preventive maintenance of machines. • Daily pre-operation inspection checks are carried out & recorded weekly as a minimum. • Check the lifting eye before lifting. • Whip check fitting attached to the hose inlet. • Lifting eye to have a compatible shackle. • Plant "nappy" under compressor. • The newest compressors are internally bound. 	2	1	2
Use of a vibrating plant Hand Arm Vibration	Y	N	N	3	2	6	<ul style="list-style-type: none"> • Plant is selected for its low vibration characteristics, and a full assessment has been carried out for tasks where vibration exposure is expected. • The intention is not to expose any operative to even the lower action value. • Drilling and vibrating concrete works of short duration. • Tools should be used for their designated purpose. • All operations have been timed for trigger times, and manufacturers' information regarding vibration has been checked against OPERC 	3	1	3

Houlihan & Co. (Excavations) Limited

OHSEQ Management System



							<p>emission test results.</p> <ul style="list-style-type: none"> As the trigger time is critical, this will be periodically checked by timing actual operations- monitoring sheets for site supervisor in vibration pack. HSE nomogram for each item of plant. In addition, equipment will be tested using an accelerometer to monitor vibration levels and trigger time (exposure) by process: the results will inform purchasing policy and decision-making regarding continuous safe use. The plant department will contact the supplier to ensure that they are aware of any engineering control measures that can be installed to minimise vibration levels. Any damaged equipment must be taken out of use and reported. All work equipment must have appropriate guards in place. If guards are missing, the item may not be used. Our vibration assessments will be on-site. We do not keep registers because it involves recording trigger time, which is usually not done properly. Our assessments are based on operations which have been timed, as trigger times, by observing operations and collecting the seconds of use as against the ancillary work where there is no vibration. We do not accept that it is a good idea to record harm rather than avoiding it. 			
Use of a plant emitting noise Noise-Induced Hearing Loss	Y	Y	N	3	2	6	<ul style="list-style-type: none"> Plant has been selected for low noise rating. Ear defenders and ear plugs are available to the workforce. Where the noise at the workplace reaches 80dBA ear protection will be worn as company policy. It is not expected that anyone will be exposed to noise of 90dBA or over, but where the level exceeds 85dBA, ear protection must be worn, and we will try to reduce the noise dose by reducing it at the source. All noisy areas display mandatory 'Ear Protection' signs. Site monitoring by process and site-specific operations if necessary. Acoustic blankets are deployed at the site boundary and/ or locally to the source, depending on ongoing monitoring and site-specific requirements. The plant department will contact the supplier to ensure that they are aware of any engineering control measures that can be installed to minimise noise levels. Any damaged equipment must be taken out of use and reported. All work equipment must have appropriate guards in place. If guards are missing, the item may not be used. Wherever possible, noise is combated at the source by enclosures and engineering controls. Acoustic enclosures and engineering controls are regularly inspected to ensure they achieve the designed noise reduction. Access to noisy areas is restricted to only those persons who have to enter the zone, thereby reducing the number of persons exposed by distance. 	3	1	3
Cutting concrete – Kerbs, slabs and other PCC items. Inhalation of respirable silica, strike by flying fragments. Vibration.	Y	Y	N	3	3	9	<ul style="list-style-type: none"> Kerbs cut in area excluding public, other operatives. physical screening positioned to protect other workers and passers-by. A battery-operated water dust suppression unit must be used on disc cutters (on diamond-tipped blades only). Correct blade used on disc cutters. Filter masks to P3 standard worn (personal issue, disposable, fit-tested). Stihl disc cutters selected for low vibration. Task will not require trigger time over lower action level. Nomogram for specific work equipment on site. COSHH assessment in place. Abrasive wheel training must be provided to all abrasive wheel users. Eye protection to BS EN166:1995 1. B will be worn 	3	1	3
Cutting Steel Strike by flying fragments, Vibration	Y	Y	N	3	2	6	<ul style="list-style-type: none"> Steel will be cut on site in a cordoned-off section clear of fire hazards, and the correct PPE will be worn. Ensure refuelling areas containing flammable substances are at least 20.0m away. 	3	1	3

Prepared by: Agron Selita	Client: Dandara Homes
Page 31 of 49	Doc: M0626 MS 2501 278 Works

Houlihan & Co. (Excavations) Limited

OHSEQ Management System



							<ul style="list-style-type: none"> • Task will not require trigger time over lower action level. • Nomogram for specific work equipment on site. • Hot works permit to be in place • Fire extinguishers to be at the workplace • Operatives to wear safety goggles • Operatives to wear ear defenders • Fire watchman to be present at all times when cutting 			
Placing concrete, backing kerbs, slabs, and strip footings Contact with wet concrete causing chemical burns, irritant or contact dermatitis	Y	N	N	2	2	4	<ul style="list-style-type: none"> • Concrete delivered ready mixed to avoid site mixing where practicable. • The chutes from RM lorries will be opened out and directed by the driver ONLY. • Mix for backing kerbs will be dry to prevent slump, which will minimise the possibility of splash. • Placing by hand from the dumper skip. PPE will include nitrile gloves and clothing to cover up arms and legs. • Standing on concrete should be avoided if possible. • Use of a vibrating poker is limited where possible and selected for low vibration. • COSHH assessment in place 	2	1	2
Lifting and placing kerbs/slabs Injury to the back from the manual handling of standard HB2 pre-cast concrete kerbs	Y	N	N	3	3	9	<ul style="list-style-type: none"> • HB2 kerbs weigh 67kg: substitution of lighter kerbs only possible if permitted in specification. • Kerb lifting wheelbarrow will be used: push force only 5kg after kerb is levered off the ground by pressing down on the handle. • Easyliifter replaces the need to use a machine in a constricted space and with passing traffic. • Transit carried out safely by Probst kerb Caddy. • Refer to the full Houlihan & Co slab/kerb laying manual handling assessment 	3	1	3
Confined spaces in manholes Asphyxiation, Poisoning from toxic gases, Injuries from exploding or igniting gases, Infection from contaminated water, e.g. Weils disease, Drowning, Back injuries from falls or collisions with structures/ fittings in the working area.	Y	N	N	3	3	9	<ul style="list-style-type: none"> • Wherever possible, consider doing the work from outside the space • A Permit to Work system should be in operation. • A detailed assessment of the task has been carried out: <ul style="list-style-type: none"> • Available ventilation • The potential for hazardous gases/atmosphere being present • Hygiene/welfare requirements. • The local rescue services have been informed of the work and where necessary, advice or inspection has been sought. (High risk operations). • Suitable detection equipment is on site and used prior to each entry and continually during the presence of people in confined spaces. • Emergency breathing apparatus and harnesses are readily available on site. • Precautions for the use of plant and equipment or heavier-than-air gases are established. • Flood potential and isolation have been checked. • Emergency procedures are fully developed and have been adequately rehearsed. • Workers must be physically fit and competent to enter and undertake work in confined spaces • Effective communication should be established between workers in the confined space and those outside the area. • The atmosphere of the confined space should be monitored for the presence of and levels of gases and must always be tested before entry. • If dangerous fumes are present, suitable breathing apparatus should be worn, and the person entering the confined space should wear a safety rope, one on each end, held by the person keeping watch outside • Equipment which may release excess oxygen, or engines which emit carbon monoxide gas, should not be used in confined spaces • Smoking, naked lights, sparking tools, and any nylon material should be prohibited • If working in contact with contaminated water, e.g. in sewers, workers must be inoculated against serious disease. Any skin cuts should be covered • Washing facilities should be available to encourage good hygiene 	3	1	3

Houlihan & Co. (Excavations) Limited

OHSEQ Management System



							<ul style="list-style-type: none"> Trenches deeper than 4.5m should be treated as confined spaces. Manholes to be vented for 30 minutes before entering. Gas monitor to be placed in manhole 30 minutes before entering. A confined space work permit is to be obtained before entering. Operatives to be briefed on escape plan. Operatives to be trained for confined space working. Top man to be present at all times. Rescue harness and tripod to be used. Escape kit to be used where necessary. Benching should be carried out with the cover slab removed to allow air entry. 			
Working with live sewers/Sewer diversions Gastroenteritis, Weils disease, Infection of the skin or eyes; and/or occupational asthma, resulting in attacks of breathlessness, chest tightness and wheezing produced by the inhalation of living or dead organisms	Y	N	N	3	3	9	All the above items are covered in Confined spaces in manholes <ul style="list-style-type: none"> Over pumping to be carried out where operatives need to enter a live sewer. Ensure that employees and line management understand the risks through proper instruction, training and supervision Waterproof gloves and overalls to be worn at all times Gas monitors to be in place Good personal hygiene Flow to be diverted where possible. Management to ensure a good welfare standard is kept on site before any live sewerage works occur. 	3	1	3
All work in the area- live services Contact with live service resulting in burns from flashover or electric shock. Toxic or flammable gases from a damaged sewer pipe. Damaged or severed pipes leading to leakage of substances, resulting in potential flood, gas leak, explosion or fire. Contact with severed fibre optic cables	Y	Y	N	3	3	9	<ul style="list-style-type: none"> A Permit to dig will be completed and authorised from client site team. Works must be undertaken as per H&Co's safe digging procedure "works on/near underground services". Operatives to receive full TBT relating to site services provided by the services coordinator prior to starting works. Cable and metal location equipment must be duly calibrated and in good working order, operatives appointed will be trained on how to locate services using the EziSystem & safe digging techniques as set out in the H&Co's works/on near underground services procedure. (Note: Lighting columns may be dormant during the day so the generator should be used to trace cables). Utility plans from network operators must be reviewed in conjunction with a visual survey to be carried out for any service covers nearby that may indicate buried services in trench line. Located services will be identified, i.e. gas, electricity, etc, and indicated clearly by the survey operative using marker paint on the ground, with depth estimations if possible. Operatives will now wear flame resistant clothing (a Nomex material by J.Ross) for all close proximity work to any exposed cable. (Note: The clothing can be used in layers to reduce the heat burden of wearing it, but as UKPN have not provided an arc flash risk assessment giving us a calorific value to inform clothing selection, we will assume worst case scenario and wear the highest level of protection). An air-pick must accompany every excavation on/near underground services to loosen up fill material & insulated tools to remove loose material only – forced digging must be avoided if ground conditions permit. No mechanical digging within 1m of a known service. All workers will practise safe digging practices when hand digging in the proximity of an underground service. For example, an air pick must always be the first tool of choice to loosen up backfill material, spades/shovels should be used, not picks or power tools, and horizontal digging should be used to locate the exact position of a cable to avoid fracturing it. All exposed services must be supported. It should be assumed that all services are "Live" until proved otherwise. If a service is struck, cease work immediately and report it to site management. 	3	1	3

Houlihan & Co. (Excavations) Limited

OHSEQ Management System



<p>Work near overhead lines Contact with live conductor, arcing</p>	Y	Y	N	3	3	9	<ul style="list-style-type: none"> The quality of backfill is important for future site users and also if a main has to be exposed for service connections- only granular material should be used, no cohesive soil, and marker tape is essential. Engineers should record sufficient data before backfill for the PAS256 recording. Control measures set out in GS6. A site visit from the DNO required establishing sag and swing, and advice on safety clearance- (GS6 survey). Routes to transit are set out with goalposts at entry and exit and sideways barriers to delineate the width of access. Working underneath will require notification to DNO, a grant of permission, probably with conditions, and limiters/ chaining back of booms, etc. or use of small plant, in either case to prevent absolute reach of plant into space above the clearance limit. 	3	1	3
<p>Presence of contaminated ground Chemical injury, skin irritants, burns, blindness, death</p>	Y	N	N	2	2	4	<ul style="list-style-type: none"> Ground conditions must be established by a survey to identify the type of ground in which the excavation is to be carried out Contaminants will be removed by a remediation contractor and validation/clearance report must be issued to us from the client. Discovery procedure in place for reporting unusual conditions not previously discovered in surveys, e.g. unusual smells, bright coloured layers in the ground 	2	1	2
<p>Constructing walls from foundation level using bricks or blocks & raising brickwork on manholes leading to Manual handling issues, Slip and trip hazards from an untidy working area Repeated contact with mortar, Collapse of brickwork/blockwork Contact with sharp edges Concrete mixers with faulty or missing guards, Silicosis.</p>	Y	N	N	2	2	4	<ul style="list-style-type: none"> Small bags of cement (25kg) should be used to minimise the risk of back injuries, etc Management should arrange for the safe delivery of materials to the work area As a result of the COSSH assessment, all operatives should be informed of the hazards of dermatitis and the control measures required to avoid contact with mortar, and good personal hygiene The operative knocking-up mortar MUST wear a P3 mask and eye protection when using the mixer Washing facilities should be available on site to ensure good personal hygiene Mechanical or electrical cement mixers should be inspected for faults before use Safe working platforms should not be required for substructure blockwork; if required, consult with the H&S department. Foundations must always be stripped to the TOC level prior to the bricklayer's arrival Where practicable, lifting aids are provided to reduce/remove the need for manual handling. Lightweight blocks are specified where possible. COSHH data sheets are readily available on-site, displayed on the OHSEQ site notice board Manual handling assessments are readily available on site. Work is halted/curtailed in inclement weather. Suitable and sufficient dust control measures are provided and used. Bricklayers' foreman should ensure bricks/blocks stacked close to the working area are on a level base and stacked to a safe working height where they cannot topple over – this should minimise bending, carrying, stretching and twisting activities, all of which can generate back injuries. Concrete blocks to be cut with a block splitter or hammer and bolster, to minimise the use of airborne dust. Eye protection must be worn when cutting/breaking blocks manually. 	2	1	2
<p>Excavations Noise / Vibration Weakening of adjacent structures Ingress of water Falls of persons Falling materials or plant Underground services – gas,</p>	Y	Y	N	3	3	9	<ul style="list-style-type: none"> Permit to Excavate will be completed and authorised by the Contractors Management. Ground conditions must be established by a survey to identify the type of ground in which the excavation is to be carried out Prior to commencement of excavation, the need for and method of support should be determined Support materials will be on site before excavation starts If there is a possibility of underground services being present, the area will be surveyed using a suitable detection instrument Excavations will be inspected prior to each shift, after any event likely to affect strength or stability, and after any accidental fall of material. A logged report must be carried out every seven days. 	3	1	3

Houlihan & Co. (Excavations) Limited

OHSEQ Management System



<p>electricity or water Toxic or flammable gas Oxygen deficiency "Boiling" Collapse of excavation Presence of contaminated ground</p>							<ul style="list-style-type: none"> No heavy plant within 2m of an unsupported excavation. Excavations should be assessed by a competent individual, nominally the site supervisor. Where necessary, the sides of the excavation will be battered to the angle of repose or stepped, making sure the step is equal to the depth of the excavation. Where an assessment establishes possible ventilation problems, a gas monitor will be utilised to monitor the atmosphere before entry Plant and materials will be kept away from the side of the excavations to prevent undue pressure or ingress of exhaust fumes Excavations must be suitably illuminated To keep the atmosphere healthy, ventilating equipment should be used in confined areas If the depth of the excavation is two metres or more, or if the depth is less but there is a particular risk of anybody falling, suitable guard-rails will be placed and suitable access arrangements, such as ladders or ramps, should be provided If there is a risk of water ingress, suitable methods and/or equipment should be provided to either prevent the entry of water or to remove water, e.g. water pumps If the plant could fall into the excavation, timber baulks should be provided Inspections of excavations will be carried out prior to each shift, after any event likely to affect strength or stability, and after any accidental fall of material Suitable gloves must always be worn when working in/around excavations. All excavations must be fenced off with suitable fencing and signage; pins and bunting/barriers may be suitable for shallow trenches. Heras Fencing should be used for deep trenches. 			
<p>Working from height with loose materials/plant Falling material, debris striking operatives/visitors</p>	Y	Y	N	2	2	4	<ul style="list-style-type: none"> Plant and materials will be kept away from the side of excavations to prevent undue pressure or ingress of exhaust fumes. If the plant could fall into the excavation, timber baulks should be provided All loose material is to be cleared at the end of every shift. No loose material to be left close to the excavation where there could be a risk of material falling. All excavations must be fenced off with suitable fencing and signage. 	2	1	2
<p>General - Manual Handling Strained/pulled muscles, abrasions, cuts, foot injuries, back strain, slips/trips/falls</p>	Y	Y	N	3	2	6	<ul style="list-style-type: none"> Assess the task; use appropriate lifting equipment / lifting accessories for the activity. Always use mechanical lifting aids where necessary. Assess the weight of the load; avoid lifting heavy loads of more than 20kg. Break the load down into smaller, lighter parts. Plan the work to avoid excessive carrying. Change the layout of the work if possible. Ensure work areas are clean and tidy, free from tripping and slipping hazards. Check individual capabilities of those carrying out manual handling operations. The weight of the load is checked before any lifting commences. Mechanical equipment such as forklift trucks, pallet trucks, trolleys, and sack barrows is used to reduce employees' handling injuries. Ensure a clear working area for general distribution and installation. Environmental conditions including unobstructed walkways, no tripping hazards, adequate lighting, etc. 	3	1	3
<p>Concrete operations. Vibration, Concrete penetration of eyes, nose or ears due to an uncontrolled surge during cleaning operations or clearing of blockages, Exposure burns to skin</p>	Y	N	N	2	2	4	<ul style="list-style-type: none"> PPE & washing facilities should be provided. Regular toolbox talk training must be provided on PPE, burn injuries, dermatitis, etc. Appropriate personal protective equipment (PPE) should be worn Coveralls to be worn whilst concreting – there should be no exposed skin. The accumulation of concrete spillage should be prevented. Glasses to be worn whilst concreting. Walking boards' are to be in place prior to slab/beams/ crane base pour commencing for safe passage of concrete workers. Concrete Poker can be used for no more than 3 hours, which is the Daily Exposure Action Value (EAV). (Daily Exposure Limit Value ELV is 	2	1	2

Houlihan & Co. (Excavations) Limited

OHSEQ Management System



















							reached over 12 hours)			
Steel fixing, shuttering & general site duties Stepping on tied-steel wire, cuts to hands from Stanley knife & various site materials, trapping fingers, sprained ankles,	Y	N	N	2	2	4	<ul style="list-style-type: none"> Exclusion zones to be erected by physical barriers prior to works commencing. Banks man to enforce exclusion zones. Steel-toe cap boots have midsole protection. NO loose correx to be left 'laying' and especially unweighted. The site fixers will clean and collect all loose tie wire as they progress to new work fronts. Automatic retractable blades are only to be used for cutting materials, such as Correx for shuttering. Suitable gloves MUST be worn; however, Gloves will not completely protect your hands, but if you do receive a cut, it may not be quite so bad. NO walking on ground beams or any other RC cages without walking boards. High-impact glasses or goggles to be worn at all times whilst cutting site materials. Task specific. Minimum FFP3 dust masks to be worn whilst cutting site timber/ply. Minimum FFP3 dust masks to be worn whilst cutting any concrete objects, including kerbs & slabs. Electronic water attachment to be in place on the cut of saws whilst cutting concrete surfaces, including kerbs & slabs. Cutting station to be fenced off and ear protection to be worn at all times. A Hot Permit must be obtained prior to any cutting taking place. 	2	1	2
Setting out with instruments / surveying with cobras/rods Slips/trips/falls, Service strikes, cobra/rod striking operative.	Y	Y	N	2	2	4	<ul style="list-style-type: none"> Read and understand the setting out and service drawings prior to setting out. Pins and stakes are only to be installed when no services are present. The site engineer must review stat plans & CAT survey the area, if services are remotely likely Pin Safe setting out instruments MUST be used. Cat scanning of the area to take place prior to excavation. Line marker paint to be stored in the COSHH storage area. Empty line marker paints to be disposed of in the empty line marker paint can in the general waste bin – ONLY IF EMPTY. Do not enter the swing radius of an excavator; adhere to exclusion zones. Operatives using the cobra reel / rods must wear eye protection & gloves at all times whilst undertaking the operation. Flashing safety lights on site can interfere with levels, necessitating the removal of machinery or turning off rotating orange lights while the plant is in the vicinity. Risk migrates to plant/ pedestrian interface: engineer/ site foreman must authorise lights off, arrange work to minimise time this is necessary and arrange banking vehicles if required. 	2	1	2
COSHH Chemical injury, skin irritants, burns, blindness, death	Y	Y	N	3	2	6	<ul style="list-style-type: none"> Refer to the COSHH Assessment for all hazardous substances to be used and brief all operatives prior to commencing work. COSHH data sheets provided when COSHH products are issued from stores Full PPE to be worn in conjunction with COSHH assessments All hazardous substances must be stored in the COSHH storage cage provided. 	3	1	3
Work near asbestos Inhalation of respirable fibres leading to mesothelioma, lung cancer	Y	Y	N	3	3	9	<p>NOTE: there is no known safe level of exposure to asbestos.</p> <ul style="list-style-type: none"> Additional MS from specialist licensed contractor who will be in attendance for monitoring and for emergency if bulk asbestos uncovered. Background air monitoring must have taken place to give a baseline, which must be a measured figure below the clearance level or undetectable. Continuous monitoring during operations with analysis continuous from on-site facility. Personal dosimeters for all personnel involved. Again with analysis in real time. Prevention of dust raised by damping down, minimising drop distances, avoiding double handling, prompt removal from site, stockpiles only if absolutely necessary and covered, on an impervious membrane. Licensed contractor operative place in case of bulk asbestos found- then stop work, re-assess and treat as licensed work, with full facility for this already on site. 	3	1	3



















Houlihan & Co. (Excavations) Limited





OHSEQ Management System



Hand laying tarmac Burns from contact with hot tarmac-delivered at 170°. Irritant or contact dermatitis	Y	N	N	3	2	6	<ul style="list-style-type: none"> Heat - resistant gauntlets to be worn. Body covered up against splash. Placing at a minimal drop distance from the dumper skip. Tools kept clean- Farvis tool heater used- no open fire or use of diesel. COSHH assessment in place 	3	1	3
Fire	Y	Y	Y	3	3	9	<ul style="list-style-type: none"> All fuels must be kept in the correct type of container that is clearly identified and labelled. No refuelling to take place in the vicinity of forms of ignition. Engines must be switched off. Do not improvise for containers or funnels. Check you are using the correct fuel. . No smoking/no naked flames. Signs to display. All Hazardous Substances must be stored in the COSHH storage. Any cutting metal, welding involving sparks or naked flame must be controlled with a Hot Work Permit 	3	1	3
Silt Management. Silt getting into the water courses and contaminating water system, damaging environmental on the water ways/ risk to aquatic life.	N	N	Y	2	3	6	<ul style="list-style-type: none"> The placement of gully protection (specially designed gully guards, or standard protection - straw and terram) in all gullies during construction, which are to be inspected and replaced/cleaned when necessary. The placement of a terram layer within all manholes during construction, and to be inspected and replaced when necessary. Minimising the movement of plant on and off roads to prevent the tracking of excess soil onto roads and highways. The installation of hardstanding areas to the front of all plots to enable 'clean' forklift access. The placement of hardstanding or topsoil at the earliest opportunity to control surface runoff from completed areas. Avoid tracking on areas of permeable paving once installed and otherwise maintain paving areas. Stripping topsoil must be done in stages to maintain as much vegetation cover across the site as possible. Retention of vegetation as far as reasonably practicable along western and south-western boundaries to promote infiltration of any surface water and silt run-off. Haul road preferably be topped with tarmac, which is easy to clean with a road sweeper. A jet wash will be installed at the site's exit to clean the wheels of vehicles leaving the site. The designated car park will be topped with stone and maintained mud-free. Silt traps and silt fencing will be strategically constructed along the site's western and southwestern boundaries to reduce runoff. These will be formed to a depth of 400mm, with excavated arisings placed on the downgradient side of the slope to aid the retention of silt and excessive surface water runoff to the detention basins. A series of Sady Matts will be placed along the watercourse to prevent any silt from going to the main water system should the silt traps placed on western and south-western boundaries alone not be sufficient to prevent run-off of surface water/silt. 	2	1	2

B 26.0						
HAND ARM VIBRATION & DECIBEL LEVEL REFERENCE CHART						
	Equipment/Plant	m/s²	Time to reach EAV 2.5m/s² (Daily Exposure Action Value)	Time to reach EVL 5m/s² (Daily Exposure Limit Value)	Sound levels	HSE Points (per 15/60 mins)
	Hilti DD130	2.2m/s ²	10hr 20mins	24hr mins	80dB(A)	2.2/10
	Hilti TE 1000	6.5m/s ²	1hr 11mins	4hr 44mins	87dB(A)	21 / 85
	Hilti TE 700 AVR	6.6m/s ²	1hr 09mins	4hr 35mins	86dB(A)	22 / 87
	Hilti AG230-S	8.7m/s ²	3hr 08mins	12hr 34mins	89dB(A)	8 / 32
	Atlas Copco 09 PE (Ver)	3.8ms ²	3hr 28mins	13hr 51mins		7 / 29
	SK12 Med Breaker	4.2m/s ²	2hr 55mins	10hr mins	108dB(A)	25/100
	Atlas Copco 230 PE	4.2m/s ²	2hr 50mins	11hr 20mins		9 / 35
	Tex 150PE Breaker	4.5m/s ²	2hr 28mins	9hr 53mins	90dB(A)	10 / 41
	Atlas Copco LT5005	6.4m/s	1hr 13mins	4hr 53mins	106dB(A)	20 / 82
	Vibrating Poker	4m/s ²	3hr 08mins	12hr 30mins	85dB(A)	8 / 32
	Wacker Plate Belle 320-574mmx320mm	2.42m/s	8hr 32 mins	>24hr	101dB(A)	3 / 12
	Wacker Plate13/40Belle 720mmx400mm	3.20m/s	4hr 53 mins	19hr 32 mins	105dB(a)	5 / 20
	Wacker Plate Belle 320-720mmx320mm	4.43m/s	2hr 33 mins	10hr 11 mins	105dB(A)	10 / 39
	MBW Plate Compactor GBX Series 3550	4.5m/s	2hr 28mins	9hr 53mins		
	Plate compactor	5.18m/s ²	1hr 52mins	7hr 27mins	93dB(A)	13.4/54
	LF75 Vibration Plate	6m/s ²	1hr 23mins	5hr 33mins		18/72

	Wacker Plate Bomag/1845	7.3m/s	0hr 56min	3hr 45mins	89dB(A)	27 / 107
	Skill saw 5903R	3.0m/s ²	5hr 33mins	22hr 13mins	95dB(A)	4.5/18
	Airsaw Toku 9''	3.6m/s	3hr 51min	15hr 26 min	82Db(A)	35
	Petrol Saw Stihl/TS410	3.9m/s	3hr 17 mins	13hr 9 mins	98dB(A)	8 / 30
	Petrol Saw Stihl/TS420	3.9m/s	3hr 17 mins	13hr 9mins	98Db(A)	8 / 30
	Petrol Saw Stihl/TS800	Left/6.5 Right3.9m/s			116dB(A)	
	Cut-off Saw Stihls	3.90m/s ²	3hr 17mins	13hr 09mins	98dB(A)	7.5/30
	Bosch Angle Grinder GWS 7-115	6.5m/s	1hr 11 mins	4hr 44 mins	91dB(A)	
	Hilti DD130	2.2m/s ²	10hr 20mins	24hr mins	80dB(A)	2.2/10
	Hilti TE 800 AVR	9m/s ²	3hr 0mins	12hr 0mins	87dB(A)	8/32
	Stirrer Drill / Paddle Mixer	3.5m/s ²	4hr 5mins	16hr 20min	87dB(A)	6 / 25
	Ausa 3t Dumper	m/s ²	hr mins	hr mins	101dB(A)	
	Thwaites 9t FTD	m/s ²	hr mins	hr mins	103dB(A)	
	Takeuchi 1.5t	m/s ²	hr mins	hr mins	93dB(A)	
	JCB 4.5t	m/s ²	hr mins	hr mins	94dB(A)	70(dBA) cab
	JCB 13t	m/s ²	hr mins	hr mins	101dB(A)	70(dBA) cab
	Doosan 14t	m/s ²	hr mins	hr mins	101dB(A)	70(dBA) cab
	Doosan 22.5t	m/s ²	hr mins	hr mins	105dB(A)	70(dBA) cab
	JCB 22t	m/s ²	hr mins	hr mins	105dB(A)	70(dBA) cab

	Bomag 135 AD	2.5m/s	8hr	>24hr	106dB(A)	
	Rammax	Remote control	hr mins	hr mins	109dB(A)	
	Bosch Angle Grinder GWS 7-115	6.5m/s	1hr 11 mins	4hr 44 mins	91dB(A)	
	Pramac 10KVA	m/s ²	hr mins	hr mins	70dB(A)	@ 7 mts
	Soil-Mech 4 piling rig	m/s ²	hr mins	hr mins	103dB(A)	
	SP11 screed pump	m/s ²	hr mins	hr mins	79dB(A)	

